

Ishwar Assandas Dialani

77, DHARMI NIWAS, R K MISSION MARG, KHAR WEST, MUMBAI 400052
Email info@smarandevlopers com

11.12.2024

TO WHOMSOEVER IT MAY CONCERN

Area of the Flat No.801 in the building Dialani Astoria is as follows.

RERA Carpet Area	616 00 Sq Feet or thereabouts
Enclosed Balcony Area	133 25 Sq Feet or thereabouts
Flower Bed Area	115 00 Sq Feet or thereabouts

Yours faithfully

Ish — A · D

(Ishwar A Dialani)

Received

(Kanabar Jayantkumar Tulsidas)

Parking Allotment

Sr No.	Flat No.	Name	Remarks
1	702	Reshmi Serrao	Sharing
2	302	Parshwa Const	
3	202	Parshwa Const	Sharing
4	502	Parshwa Const	
5	1002	Parshwa Const	
6	1002	Parshwa Const	
7	601	Amman M Sehdev	Sharing
8	602	Ramman M Sehdev	
9	901	Surendra Hegde	Sharing
10	902	Sharmila Hegde	
11	101	Cassilda D'souza	Sharing
12	102	Irene D'souza	
13	302	Parshwa Const	Sharing
14		Visitors Parking	
15	401	Ishwar A Dialani HUF	Sharing
16	402	Sadhna Ahuja	
17	701	Parshwa Const	Sharing
18	502	Parshwa Const	
19	1001	Parshwa Const	
20	202	Parshwa Const	
21	801	Ishwar A Dialani	

M. A. /
26/11/2021

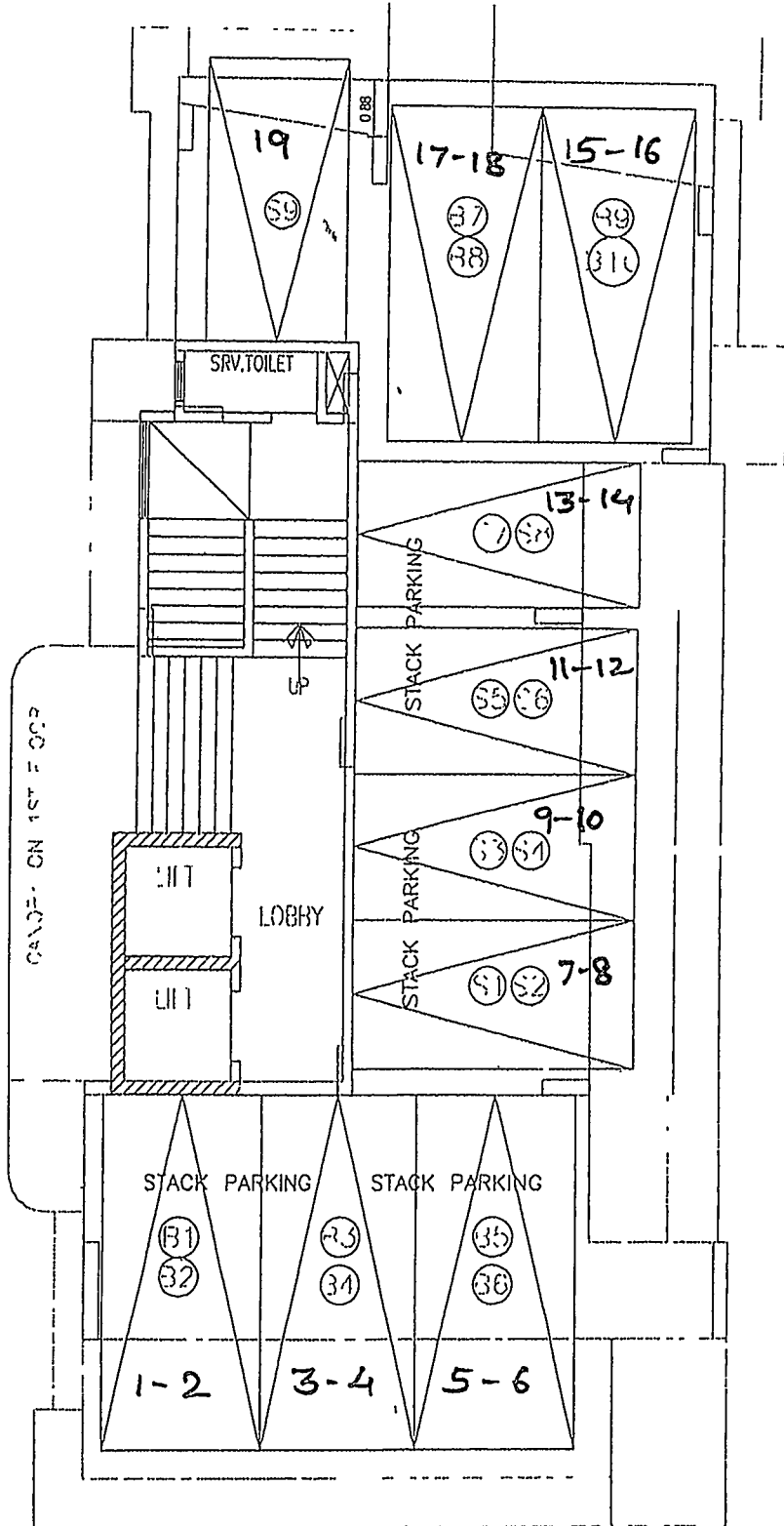
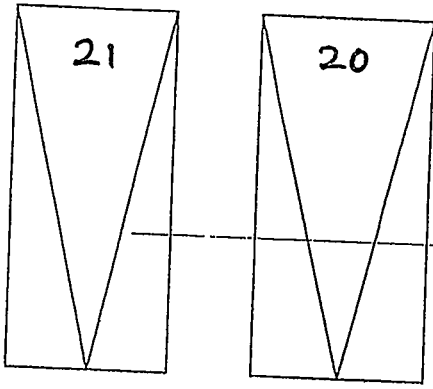

Parshwa Construction

77, Dharmi Niwas, R. K. Mission Marg, Khar (W), Mumbai - 400 052.

To,

Mr. Ishwar A. Dialani

77, Dharmi Niwas,

R. K. Mission Marg

Khar (West),

Mumbai- 400052

30th December, 2020

Sir/ Madam,

Re: (1) Agreement for Sale dated 30th December 2020 executed by and between ourselves as the Builders therein and yourself/ves as the Flat Purchaser/s therein for Flat Premises Nos. 801 in the building, "Dialani Astoria".

(2) Allotment of car-parking space to you.

1. We do hereby allot to you parking for one car in car parking Space No. "21" in the compound of the building, "Dialani Astoria" constructed by us on our property, more particularly described in the First Schedule of the Flat Sale Agreement hereinabove, situate at Kole- Kalyan, in accordance with the sanctions, permissions, plans and specifications, as approved by the Municipal Corporation of Greater Mumbai and in accordance with the said Flat Sale Agreement.
2. You are therefore with effect from the date of receipt hereof by you, bound and liable to park your vehicle/s strictly in the said car parking space allotted to you and you shall not park your vehicle/s in any other car parking space or open area of the building.

Yours faithfully,

For PARSHWA CONSTRUCTION



Authorised Signatory

Encl :

1. Copy of Parking Plan.



बृहन्मुंबई महानगरपालिका

करनिर्धारण व संकलन खाते

मालमत्ता करदेयक

बृहन्मुंबई महानगरपालिका अधिनियम, 1888 मधील कलम 200 अन्वये बजावण्यात आलेले मालमत्ता कराचे देयक.

Inward No

लेखा क्रमाक HE2402330210015	मालमत्ता करवर्ष / देयक कालावधी 2024-2025 01/04/2024 ते 31/03/2025	देयक क्रमाक 202410BIL22525460 202420BIL22525461	देयक दिनाक 13/09/2024
--------------------------------	---	---	--------------------------

पक्षकाराचे नाव व पत्ता M/S PARSHWA CONSTRUCTION FLAT N 801, DIALANI ASTORIA, VAKOLA PIPE LINE ROAD, BEHIND ST ANTHONY CHURCH, SANTACRUZ(E), MUMBAI-400055	प्रेषक - Asstt Assessor & Collector, H East Ward, Municipal Office Building, Plot No 137, TPS - 5, Road No 2, Prabhat Colony, Santacruz (East), Mumbai - 400 055 ईमेल पत्ता-aache ac@mcgm gov in दूरध्वनी क्र.022 2617 3198
---	---

मालमत्ता क्रमाक, सी.टी.एस क्रमाक / प्लॉट क्रमाक, गावाचे नाव, मार्ग क्रमाक, मार्गाचे नाव, मालमत्तेचे वर्णन, इमारतीचे नाव, करदात्याची नावे
2643A, VILLAGE KOLEKALYAN, 2643B 2662 2663A, VAKOLA PIPE LINE ROAD, RCC BUILDING OLD AC NO HE2402330040000 DIALANI ASTORIA

प्रथम करनिर्धारण दिनाक 22/03/2016	जलजोडणी क्रमाक -	User Category* - RnR
--------------------------------------	---------------------	----------------------

एकूण भाडवली मूल्य ₹ 4205195/-	एकूण भाडवली मूल्य (अक्षरी) ₹ Forty Two Lakh Five Thousand One Hundred Ninety Five Only
----------------------------------	---

कराचे नाव	01/04/2024 ते 30/09/2024 (202410) Bill Amount (₹)	01/10/2024 ते 31/03/2025 (202420) Bill Amount (₹)
सर्वसाधारण कर (General Tax)	2313	2313
जल कर (Water Tax)	0	0
जल लाभ कर (Water Benefit Tax)	1451	1451
मलनि सारण कर (Sewerage Tax)	0	0
मलनि सारण लाभ कर (Sewerage Benefit Tax)	903	903
म.न.पा शिक्षण उपकर (Mun Edu Cess)	841	841
राज्य शिक्षण उपकर (State Edu Cess)	736	736
लेझगास्वहमी-उत्पन्न (EGG)	0	0
वृक्ष उपकर (Tree Cess)	42	42
पथ कर (Street Tax)	1052	1052
एकूण देयक रक्कम (Total Amount)	7338	7338
अनधिकृत बांधकामावरील कलम 152 अ नुसार दंडाची रक्कम (Penalty u/s 152A on unauthorized construction)	0	0
आगाऊ अधिदानाचे समायोजन (Adv.Adj Amt)	0	0
भरावयाची निव्वळ रक्कम (Total Amt.)	(A) 7338	(B) 7338
अक्षरी रुपये (Bill Amount)	₹ Seven Thousand Three Hundred Thirty Eight Only	₹ Seven Thousand Three Hundred Thirty Eight Only
प्रतिदानाची निव्वळ रक्कम (Refund Amt)	0	0
अंतिम देय दिनांक (Due Date)	12/12/2024	31/12/2024
To make payment through NEFT: (Payment done through NEFT will be collected against oldest bills first) IFSC - SBIN000300, Beneficiary A/C No:- MCGMPTHE2402330210015 , Name-BMC Property Tax.	(C) दि 13/09/2024 या तारखेपर्यंतची थकव्याकी	367
	(D) दि 13/09/2024 या तारखेपर्यंतची शास्ती आणि शुल्क	0
To make payment through Cheque/DD/PO instrument should be drawn in favour of BMC / बृहन्मुंबई महानगरपालिका	(E) दि 13/09/2024 या तारखेपर्यंतची शास्तीसह एकूण रक्कम (A+B+C+D)	15043

सदरचे मालमत्ता कर देयक हे मुंबई महानगरपालिका अधिनियम, १८८८ मध्ये कलम १५४ (1ड) चा अंतर्भाव होण्यामापेक्षा जारी करण्यात येत आहे

मान. न्यायालयीन निर्णयानुसार भाडवली मूल्य विधिते निरुद्ध २०१० व २०११ मधील नियम क्र २०, २१ व २२ रद्दवातल ठरविण्यात आले आहेत. सदर देयक हे सरकात्मक आधारावर जारी करण्यात आलेले असेल, मुद्रांकनाचे विधेप्रमाणे धोरण जाहीर झाल्यावर त्यानुसार पूर्वलक्षी प्रभावाने मालमत्ताचे मूल्यांकन / फेरमूल्यांकन व त्यानुसार करवसुली करण्याचा महानगरपालिकेचा अधिकार राखून ठेवण्यात येत आहे. या सदरमधील अधिक माहिती महानगरपालिकेच्या संकेतस्थळावर उपलब्ध आहे

Scan to open BMC Website

2024
30/09/24
मुद्रांकन दिनांक २० सप्टेंबर २०२४ रोजी
वेळ : सकाळी ७ ते साय. ६

महेश पाटील
करनिर्धारक व संकलक



BRIHANMUMBAI MAHANAGAR PALIKA

Assessment and Collection PG

Received with Thanks from :-

Billing Name : M/S. PARSHWA CONSTRUCTION

Assessee's Name : DIALANI ASTORIA

PG.Trn No.10011702024121001457

Date : 10/12/2024 14:58:31

Receipt No : 2024ACR05083359

Tax Property

Account No HE2402330210015

State Code	PAN No.	GST No.	UIN No.	Place of Supply	Registered

Bill No.	Bill Dt.	Amount	ND+W.Fee+M.Pnfty+G.Pnfty+ Dischg.F.+Unlawful+Adm.	Total Dues	Early Bird Discount	Net Payable	Cash/ Chq Amt.
202220BIL15977823	01/10/2022	7338	0+0+0+0+0+0+0	367	0	367	367
202410BIL22525460	13/09/2024	7338	0+0+0+0+0+0+0	7338	0	7338	7338

Seq.No. Instrument type Date No. MICR No. Bank Status Amount
 1/ e-Pay/ 10/12/2024/ 802691671111 7705 Online Payment(CC) ----- 7705 0 7705 7705

Net Amount	CGST	SGST	UGST	IGST	Gross Value
7705	0	0	0	0	7705

Total In Words: Seven Thousand Seven Hundred Five Only

Advance Payment

Remark : Full Payment

Type of Collection

HSN/SAC NO. . 999111

MCGM PAN NO. : AAALM0042L

MCGM GST NO. : 27AAALM0042L3Z4

Created Bystate Bank of India

Printed By :By Portal/Online

Printed On :10/12/2024 14:58

Note - All amount in Rupees

Page 1 of 1

MAC-