

GROUND TO 11TH FLOOR B.U.A. DIAGRAM AND CALCULATION. B.U.A. SUMMARY. RERA CARPET AREA DIAGRAM AND CALCULATION. ST CASE LIFT LOBBY AREA DIAGRAM AND CALCULATION. REFUGES AREA DIAGRAM AND CALCULATION. PROPOSED B.U.A. STATEMENT TABLE NO. I. FUNGIBLE COMPENSATORY AREA STATEMENT TABLE NO. III. PARKING SPACES STATEMENT TABLE NO. IV.

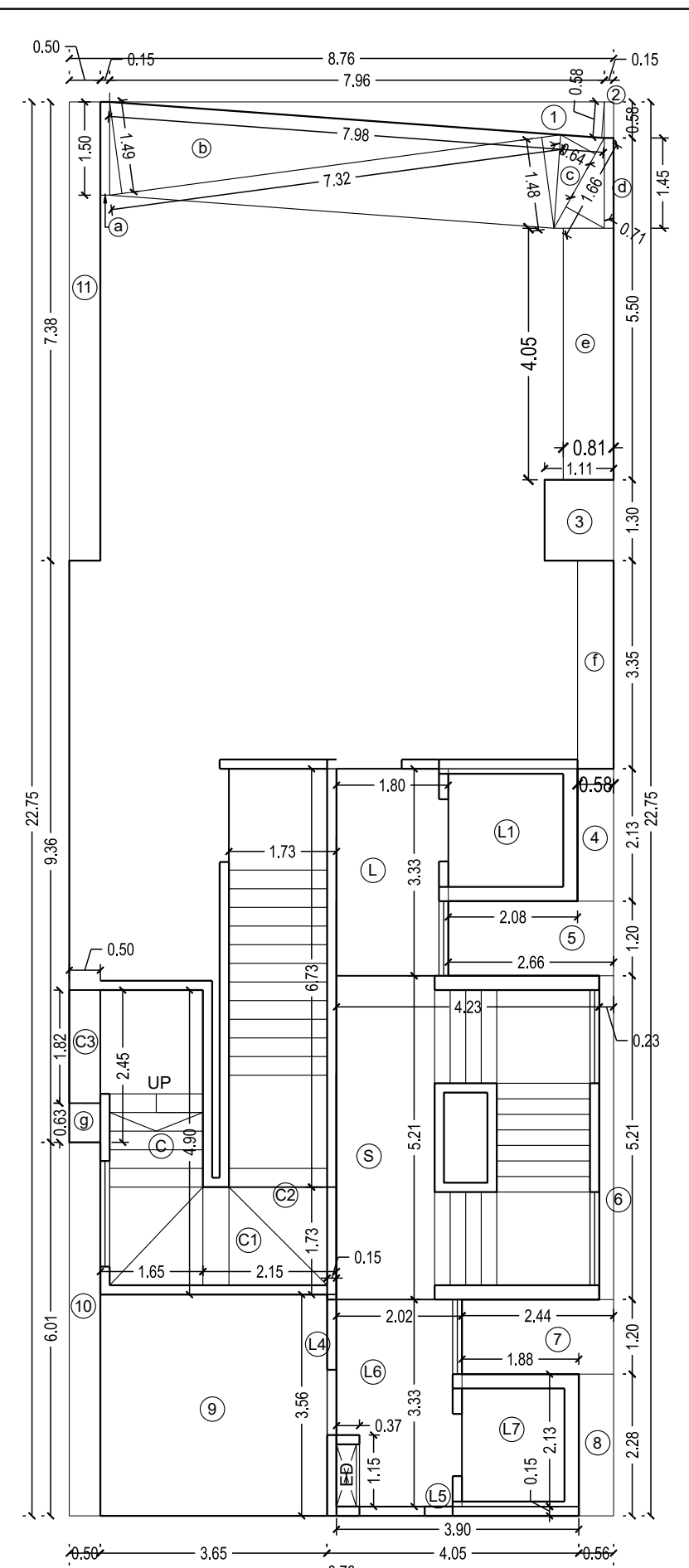

Built up area diagram of Ground & 1st floor. Scale: 1:100

BUILT UP AREA CALC. OF GROUND FLOOR

Table with columns: NOS., LENGTH X WIDTH, IN SQMTRS. Includes addition and deduction tables for ground floor area calculation.

BUILT UP AREA CALC. OF 1ST FLOOR

Table with columns: NOS., LENGTH X WIDTH, IN SQMTRS. Includes addition and deduction tables for 1st floor area calculation.

BUILT UP AREA CALC. OF 3RD FLOOR

Table with columns: NOS., LENGTH X WIDTH, IN SQMTRS. Includes addition and deduction tables for 3rd floor area calculation.

BUILT UP AREA CALC. OF 4TH TO 6TH, 8TH TO 10TH FLOOR

Table with columns: NOS., LENGTH X WIDTH, IN SQMTRS. Includes addition and deduction tables for 4th to 6th and 8th to 10th floor area calculation.

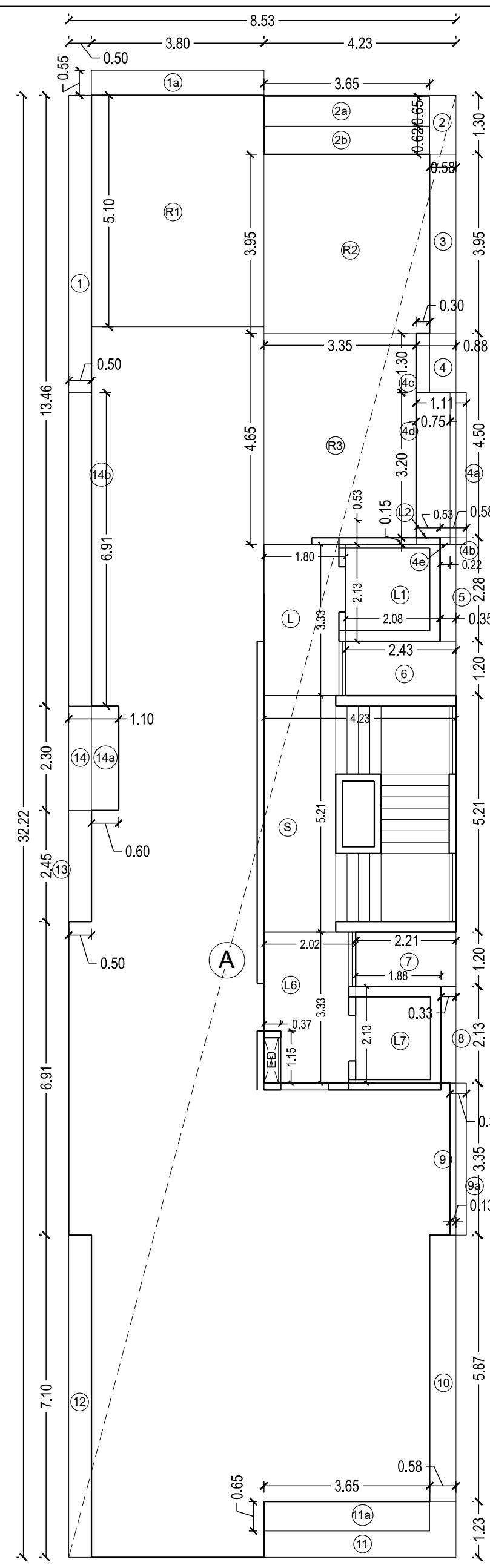

Built up area diagram of 2nd to 11th floor. Scale: 1:100

BUILT UP AREA CALC. OF 2ND FLOOR

Table with columns: NOS., LENGTH X WIDTH, IN SQMTRS. Includes addition and deduction tables for 2nd floor area calculation.

BUILT UP AREA CALC. OF 7TH FLOOR

Table with columns: NOS., LENGTH X WIDTH, IN SQMTRS. Includes addition and deduction tables for 7th floor area calculation.

BUILT UP AREA CALC. OF 11TH FLOOR

Table with columns: NOS., LENGTH X WIDTH, IN SQMTRS. Includes addition and deduction tables for 11th floor area calculation.

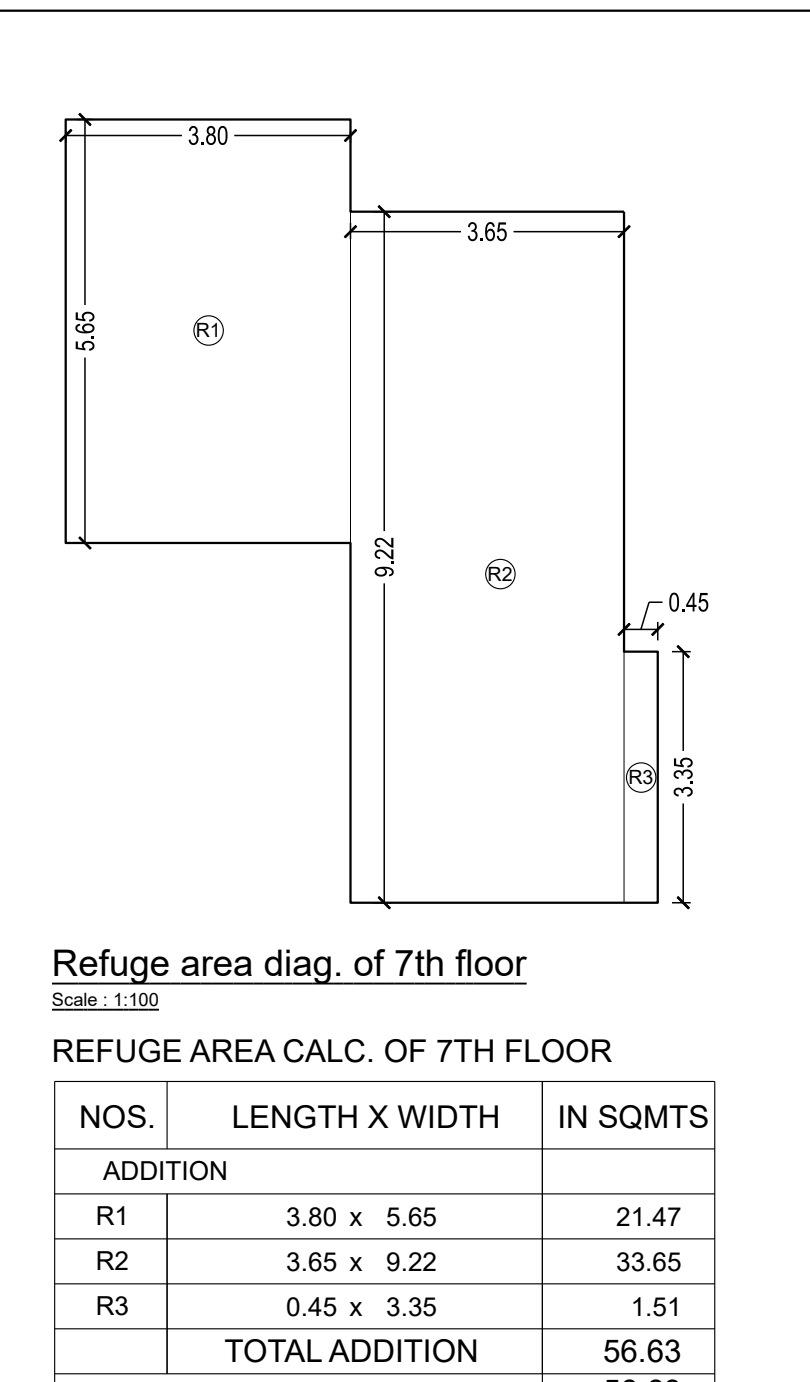

Refuge area calc. of 7th floor. Scale: 1:100



Rera carpet area calc. of 2nd floor. Scale: 1:100

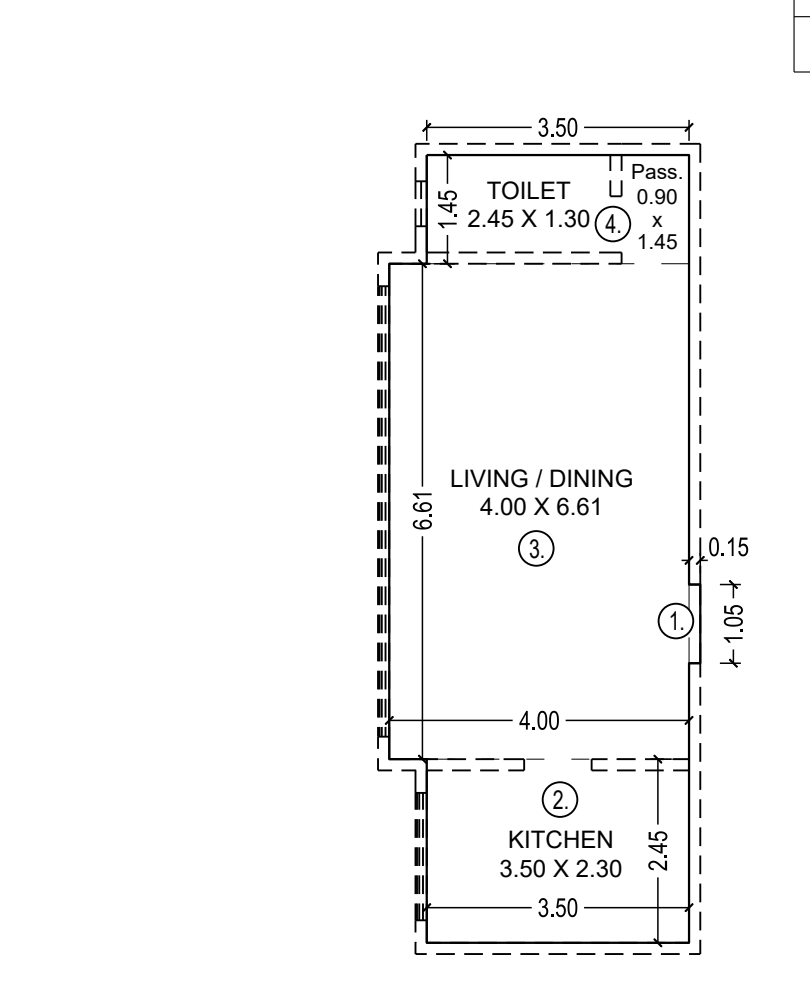

Rera carpet area calc. of 3rd floor. Scale: 1:100

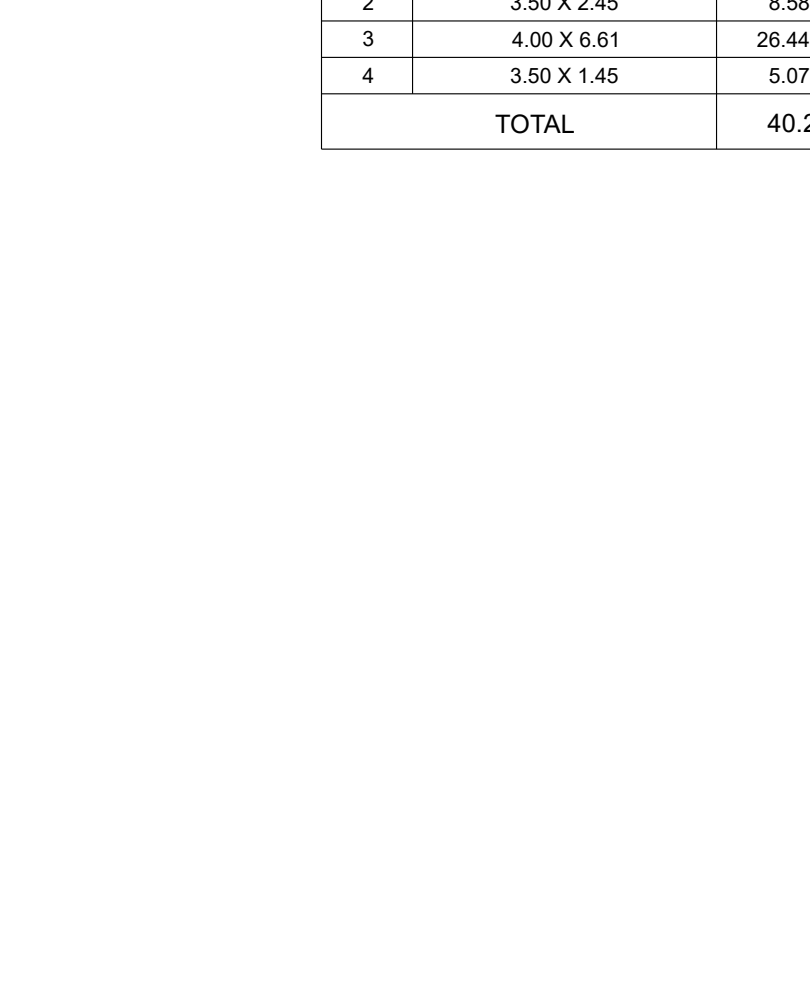

Rera carpet area calc. of 4th to 6th, 8th to 10th floor. Scale: 1:100

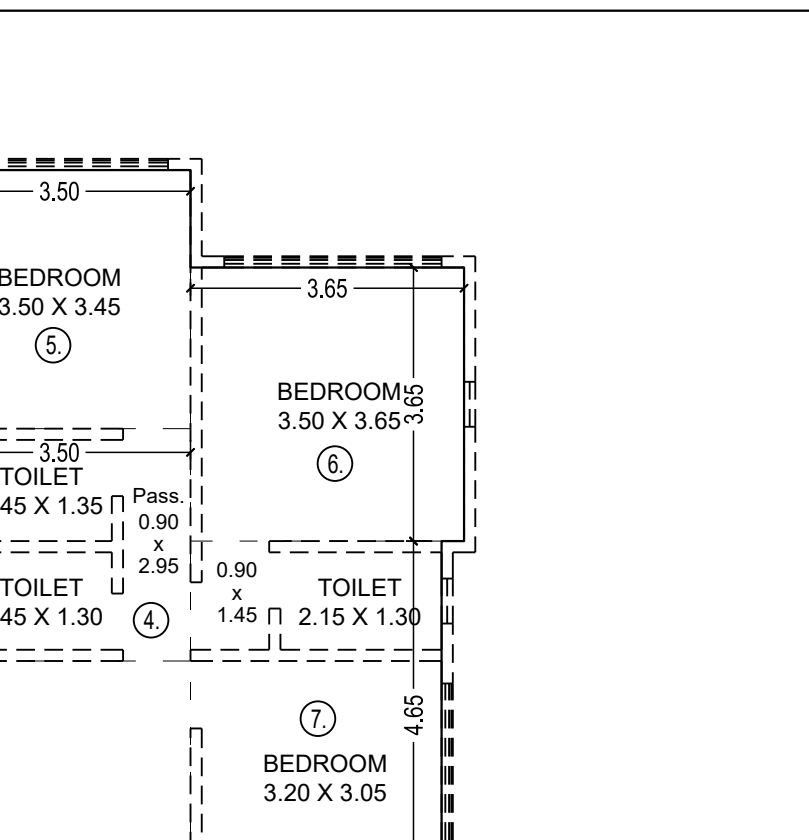

Rera carpet area calc. of 11th floor. Scale: 1:100

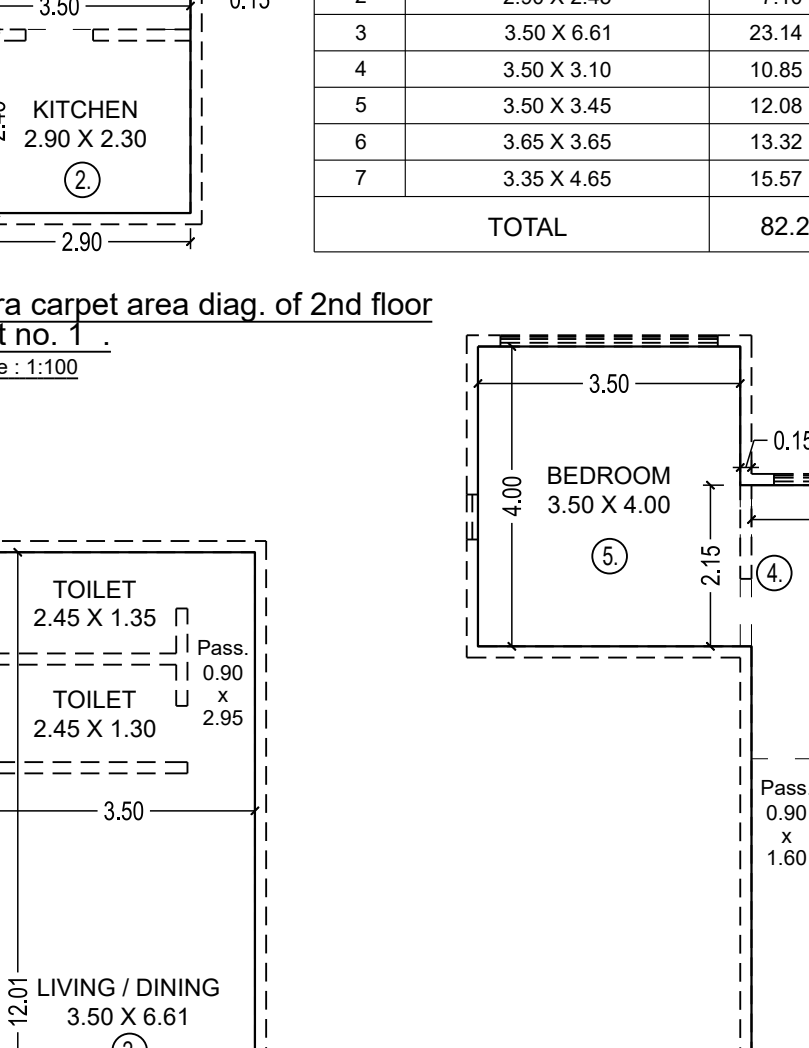

Rera carpet area calc. of 2nd to 10th floor. Scale: 1:100

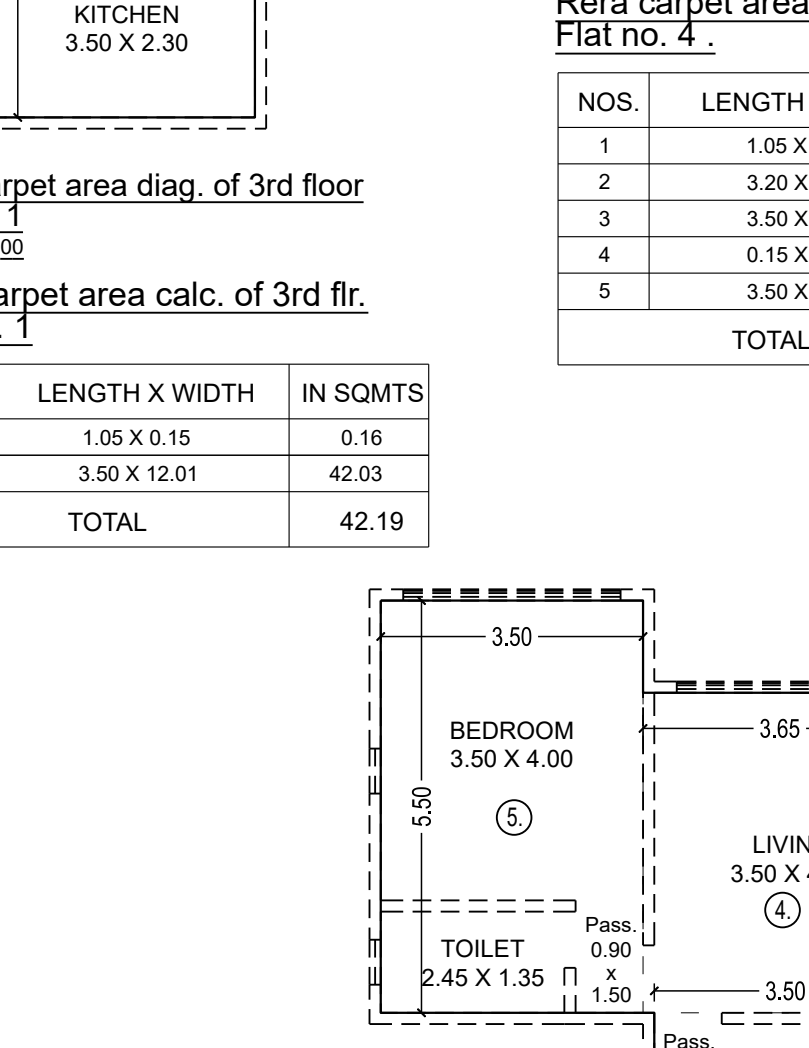

Rera carpet area calc. of 11th floor. Scale: 1:100

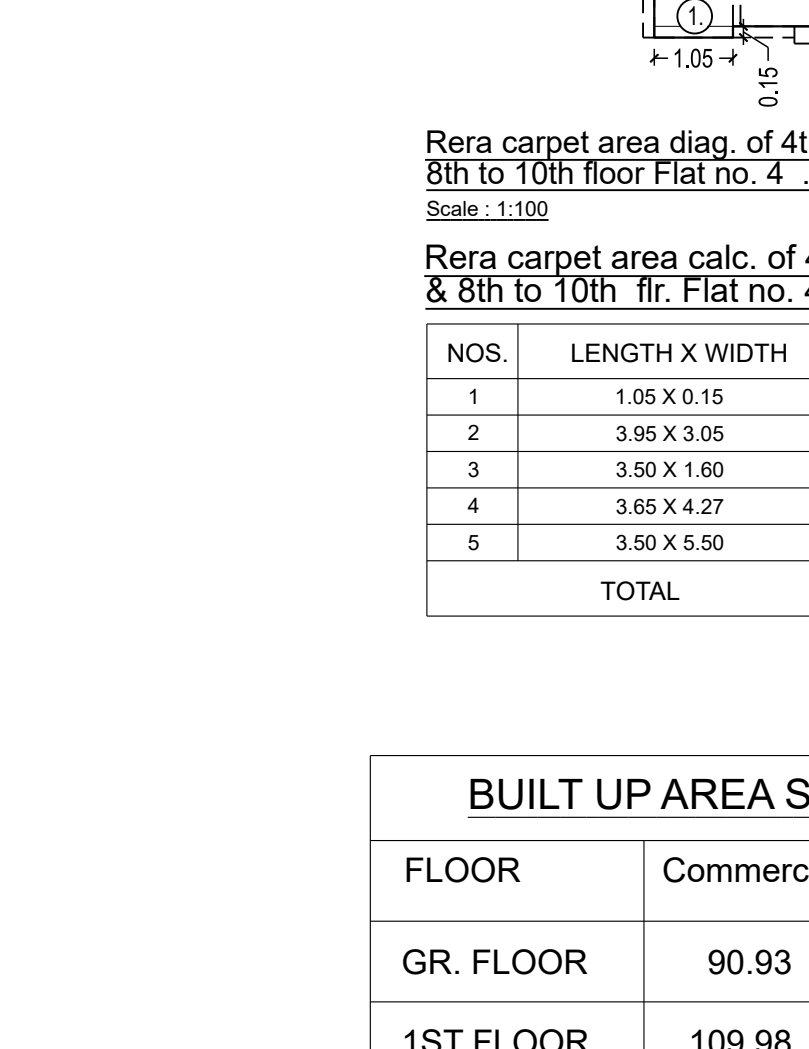

Rera carpet area calc. of 11th floor. Scale: 1:100



Rera carpet area calc. of 11th floor. Scale: 1:100

BUILT UP AREA SUMMARY table with columns: FLOOR, Commercial, Residential. Lists area calculations for each floor from GR. FLOOR to 11TH FLOOR and a TOTAL.

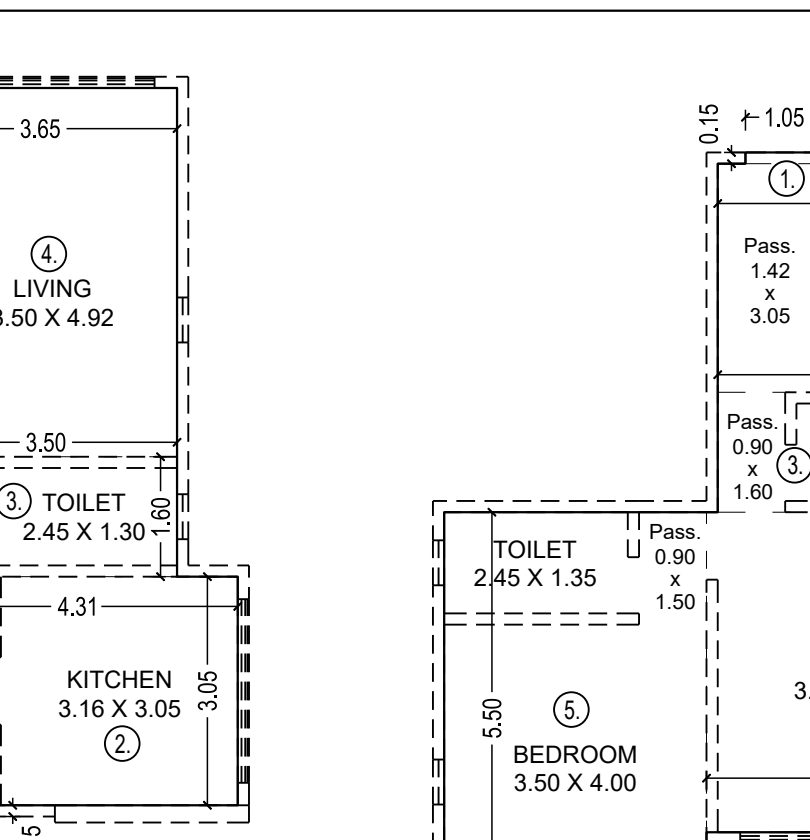

ST-CASE AREA CALC. 1 1ST FLR.

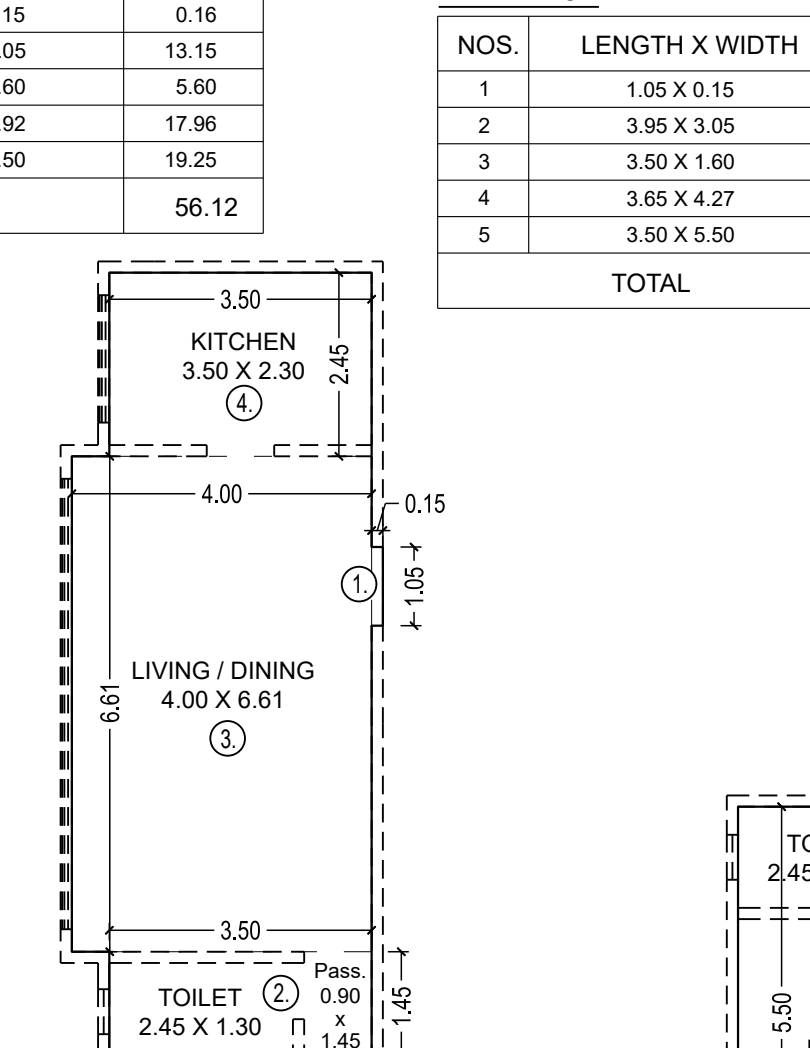

ST-CASE AREA CALC. 1 2ND FLR.

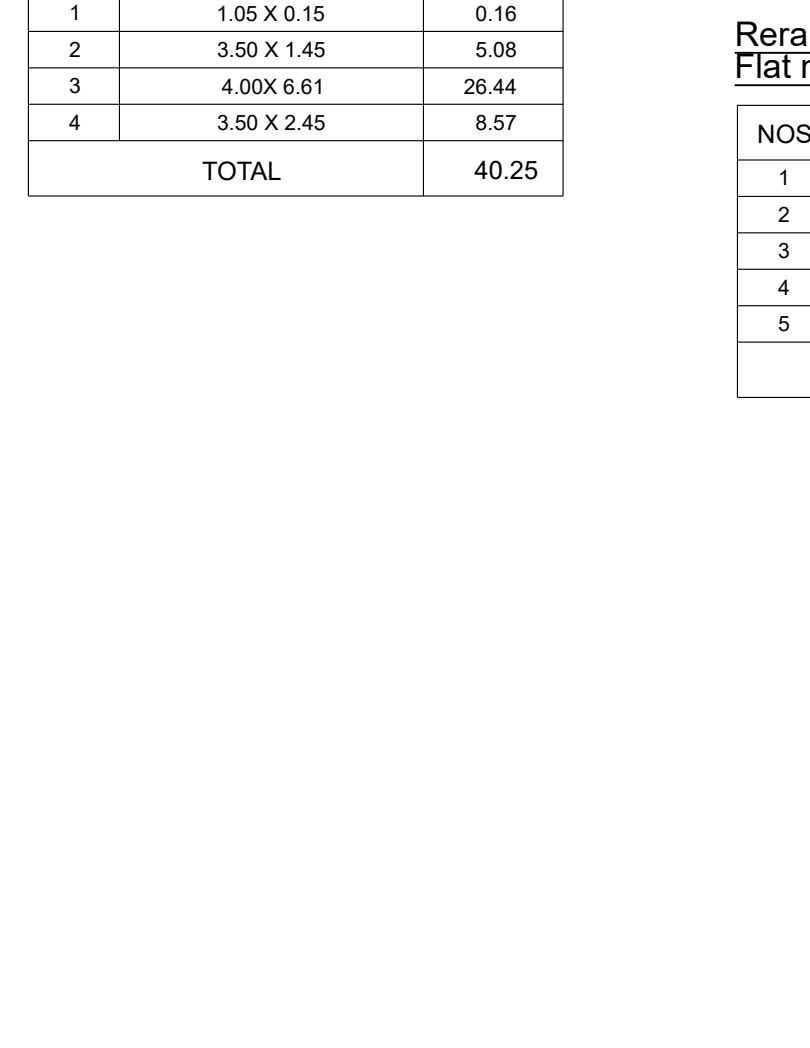

ST-CASE AREA CALC. 1 3RD FLR.

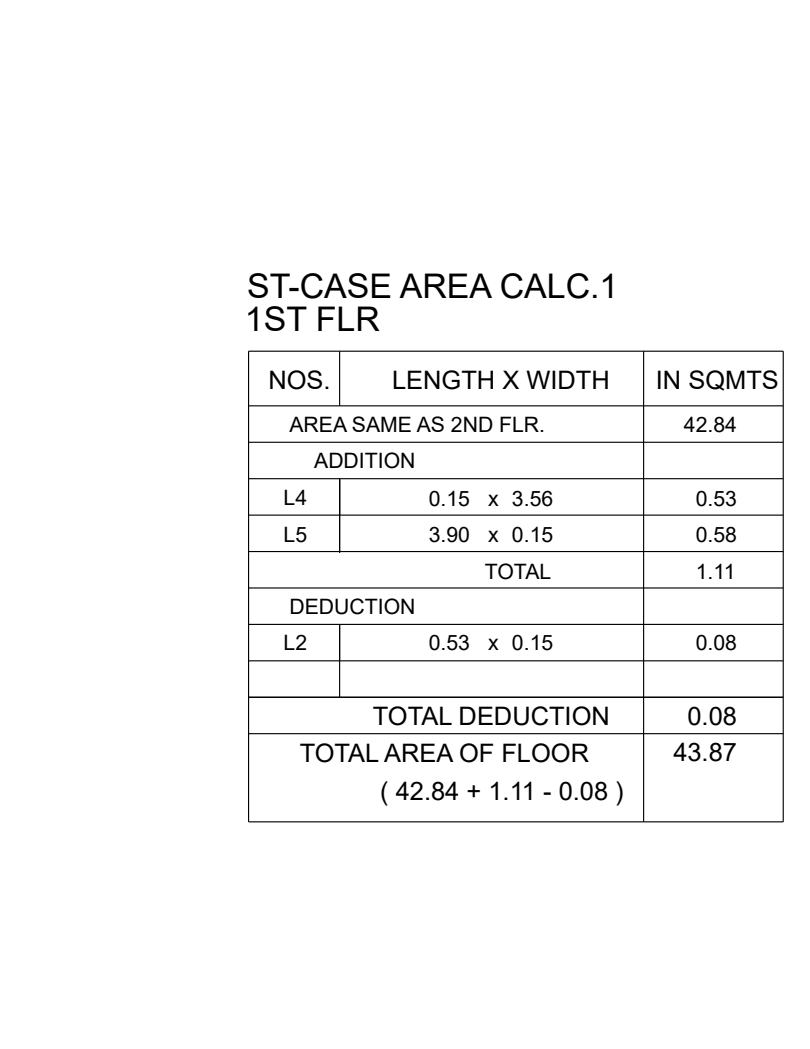

ST-CASE AREA CALC. 1 4TH TO 11TH FLR.

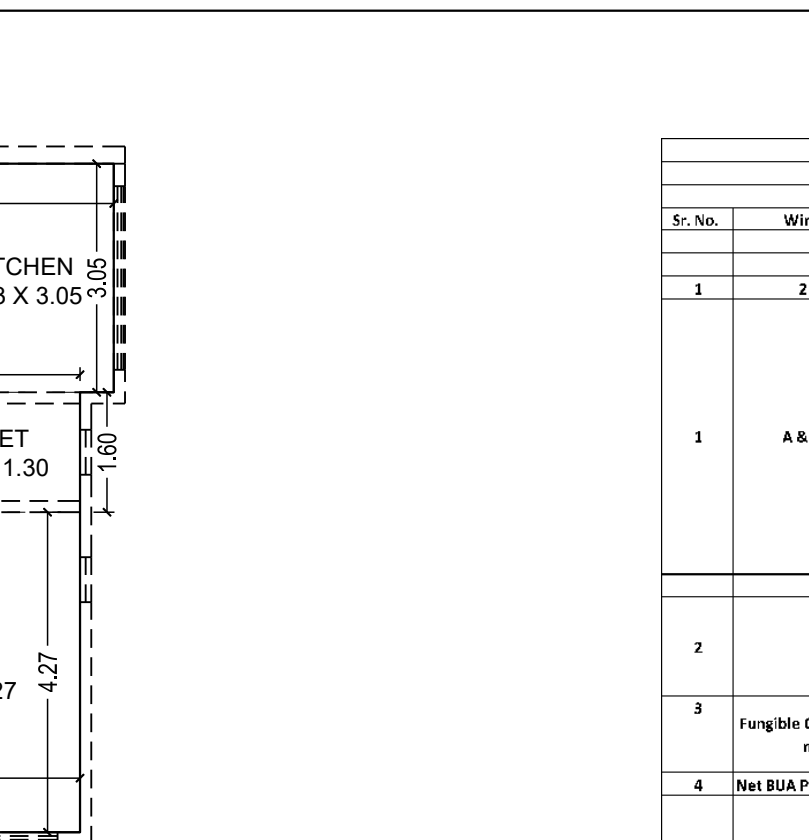

ST-CASE AREA CALC. 2 GRD. FLR.

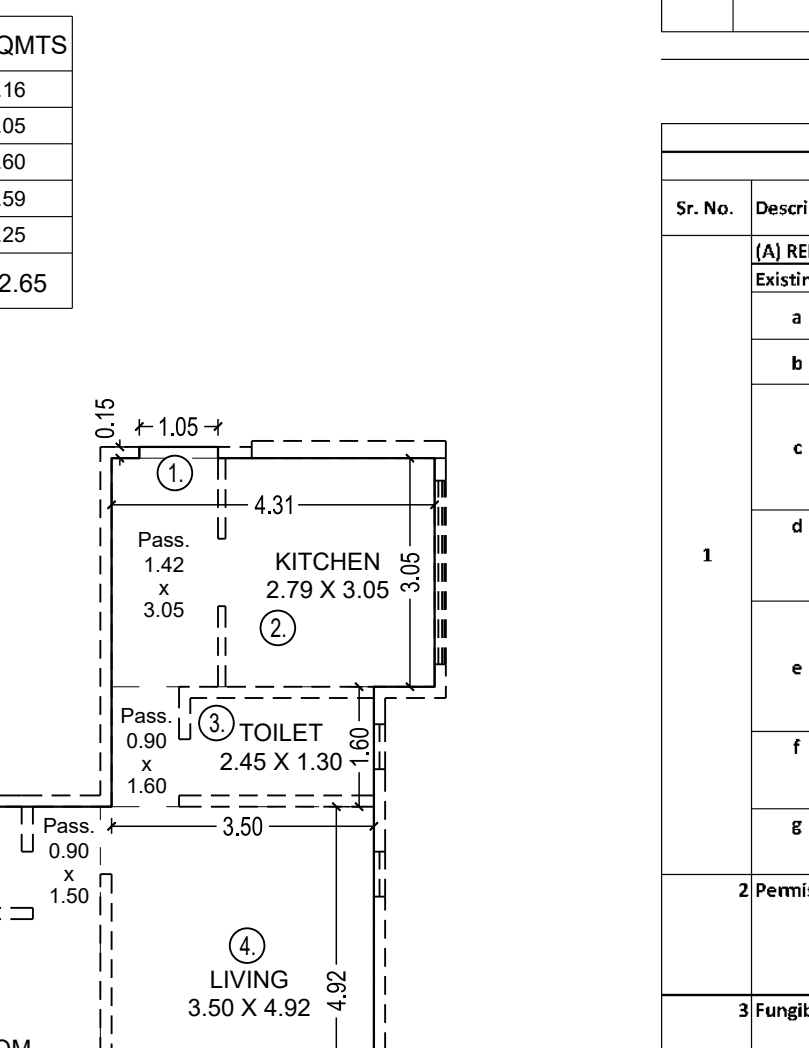

ST-CASE AREA CALC. 2 1ST FLR.

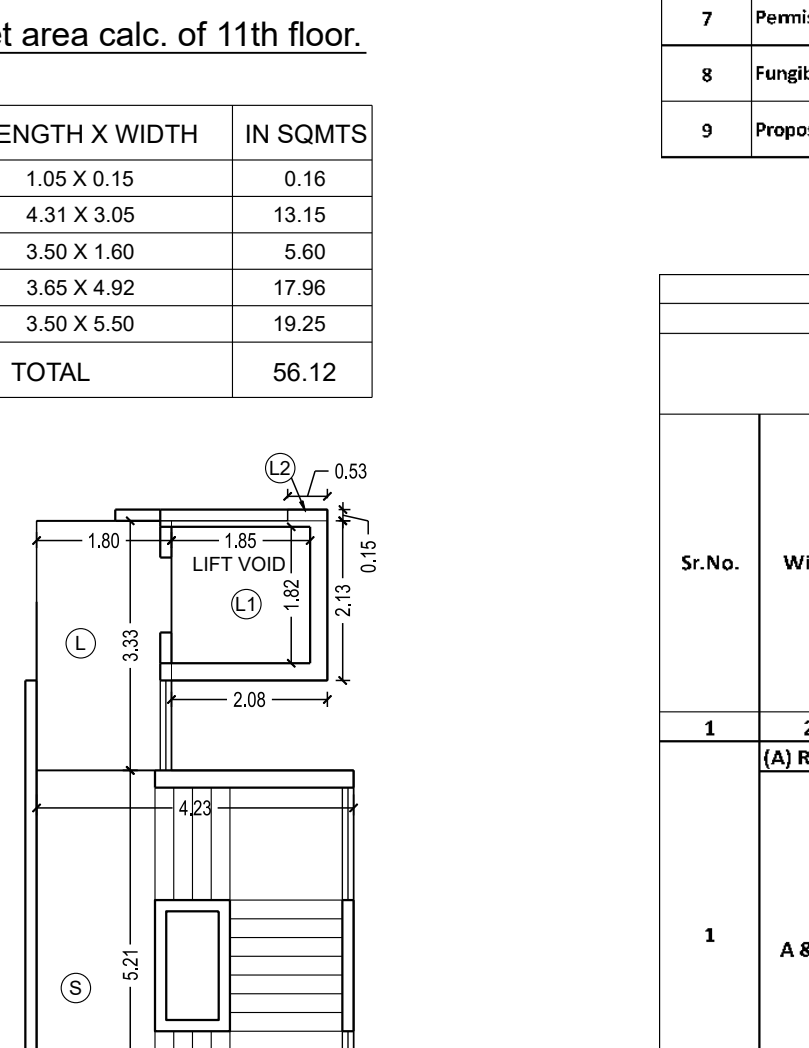

ST-CASE AREA CALC. 2 2ND FLR.

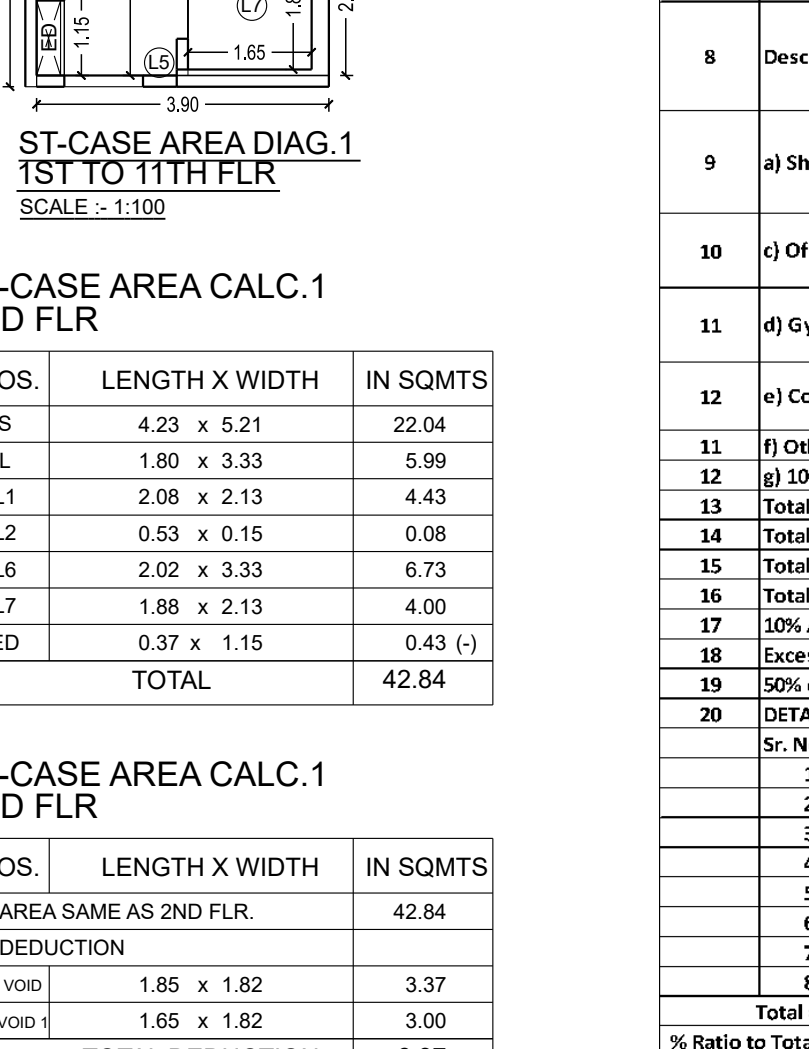

ST-CASE AREA CALC. 2 3RD FLR.

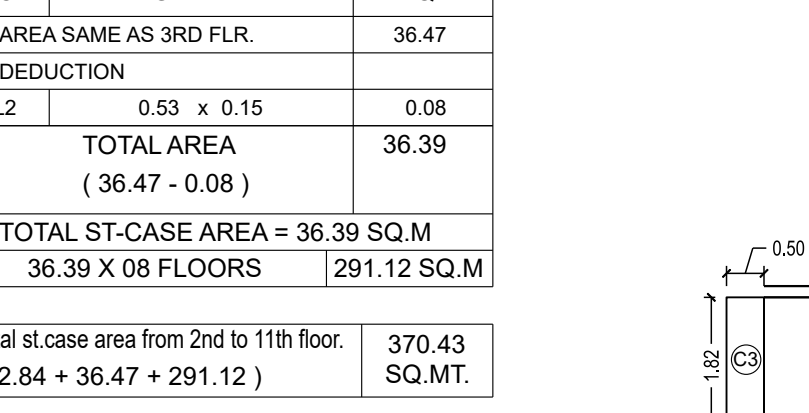

ST-CASE AREA CALC. 2 4TH TO 11TH FLR.

Table with columns: Sl. No., Wing, Floor, Proposed B.U.A. (sq. mtrs.), Residential, Commercial, Residential. Includes a summary row for 'Total B.U.A. Proposed'.

Table with columns: Sr. No., Description, Commercial, Residential, Total. Includes a summary row for 'Permissible BUA'.

Table with columns: Sr. No., Wing, Floor, Carpet Area of Tenement in sq.mtrs., No. of Tenement proposed per floor, Below 60 sq.mtrs., Above 60 to 90 sq.mtrs., Above 90 to 120 sq.mtrs., Above 120 sq.mtrs., Total Parking. Includes a summary row for 'Total'.

Table with columns: Sr. No., Description, BUA in sq.mtrs., No. of Parking Required. Includes a summary row for 'Total'.

Table with columns: Sr. No., Description, BUA in sq.mtrs., No. of Parking Required. Includes a summary row for 'Total'.

DESCRIPTION OF PROPERTY

PROPOSED REDEVELOPMENT ON PLOT BEARING SUB PLOT NO. 5 OF OLD F.P.NO. 624 (5/624) AND NEW F.P. NO. 620B OF TPS BORIVALI III, AT SHIMPOLI ROAD KASTUR PARK, BORIVALI (W), MUMBAI 400092. KNOWN AS 'SYNDICATE BANK EMPLOYEES ADARSH CHSL.'

NAME & ADDRESS OF OWNER OF THE PROPERTY

SYNDICATE BANK EMPLOYEES ADARSH CHSL. SUB PLOT NO. 5 OF OLD F.P.NO. 624 (5/624) AND NEW F.P. NO. 620B OF TPS BORIVALI III, AT SHIMPOLI ROAD KASTUR PARK, BORIVALI (W), MUMBAI 400092.

NAME & ADDRESS OF C.A. TO OWNER

M. ANAND MODI. DIRECTOR. MODI SPACES REAL ESTATE PVT. LTD. C.A. TO SYNDICATE BANK EMPLOYEES ADARSH CHSL.

NAME & ADDRESS OF STRUCTURAL ENGINEER

P. M. K. SURYA. SURYA ASSOCIATES.

Shubham Flora, 3rd Floor, Chakala, Andheri(E), Mumbai.

BUILDING PROPOSAL FILE NO. P-19832/2023(620B) R/C WARD / FP

Table with columns: DRG. NO., JOB. NO., DATE.

STAMP OF DATE OF APPROVAL OF PLANS

THIS DRAWING SHALL BE READ IN CONJUNCTION WITH INTIMATION OF DISAPPROVAL ISSUED UNDER SECTION 340 OF MMC, ACT 1988 UNDER NO. P-19832/2023(620B) R/C WARD / FP. SIGNED ON EVEN DATE.

NOTES: This drawing is digitally signed, hence no physical signature is required.

Digital signatures of Swapnil Bhagwat at Patil and Santosh Uttamrao Raute.

S.E. (B.P.) P1, A.E. (B.P.) R-II, E.E. (B.P.) WS-II R'-1. NORTH, SCALE, CHKD BY, DRN BY, HRISHI.

Digital signature of Vinita Nandakumar Chogle, Architect, CHOGLE & ASSOCIATES.