

STAMP APPROVED

AREA STATEMENT

1. AREA OF THE PLOT AS PER SITE	249.56
2. AREA OF THE PLOT AS PER 712	249.56
3. TOTAL F.S.I PERMISSIBLE	8.5
4. TOTAL PERMISSIBLE FLOOR AREA	124.78
5. PROPOSED B.U.P AREA	118.654
6. BALANCE AREA	6.126
7. TOTAL BUILT UP AREA CONSUMED (4+5)	118.654

SQ M

CERTIFICATE OF AREA
 CERTIFIED THAT THE PLOT UNDER REFERENCE WAS SURVEYED IN ACCORDANCE WITH THE PROVISIONS OF SECTION 109 OF THE PLOT STATISTICS ACT, 1956 MEASURED ON SITE AND THE AREA AS WORKED OUT TALLIES WITH AREA STATED IN DOCUMENT OF 712 EXTRACT

- SPECIFICATIONS**
- RCC FRAMED STRUCTURE
 - BRICK WALL IN CEMENT SAND MORTAR 1:3
 - EXTERNAL SAND FACED PLASTER AND CEMENT PAINT.
 - INTERNAL SAND FACED PLASTER AND CEMENT PAINT.
 - WATER TIGHT JOINTS FOR FLOORING
 - GLAZED CERAMIC TILES FOR TOILET (TUBEN TRAY) WORK
 - KOTA STONE IN TOILET FLOOR
 - WOOD DOOR FRAMES AND FLUSH PANELLED DOOR
 - ALUMINIUM SLIDING WINDOWS
 - KITCHEN PLATFORM IN GRANITE STONE. S.S SINK
 - GLASS DOOR FOR WATER SUPPLY
 - GLASS DOOR FOR TOILET
 - GLASS DOOR FOR TOILET
 - M.S. SCREENS FOR WINDOW GRILLS AND RAILINGS
 - SEPTIC TANK AND SOAK PIT FOR SEWAGE DISPOSAL
 - R.C.C. OVERHEAD WATER TANK

SCHEDULE OF OPENINGS

SR NO	TYPE	SIZE	DESCRIPTION
1	M.D	2.00 X 2.10	T.W. PANELLED DOOR
2	D	0.90 X 2.10	T.W. PANELLED DOOR
3	D	0.75 X 2.10	T.W. PANELLED DOOR
4	F.D	1.80 X 2.10	T.W. PANELLED DOOR
5	W	1.20 X 1.20	ALU. SLIDING WINDOW
6	W	1.80 X 1.20	ALU. SLIDING WINDOW
7	W	1.80 X 1.20	ALU. SLIDING WINDOW
8	V	0.60 X 0.60	ALUMINIUM VENTILATOR

PROPOSAL
 PROPOSED BUNGLOW PLAN ON PLOT NO 14 REV. SANSARI CAMP TALKER DIST. NASHIK
 FOR MR. NARENDRA A. PATIL

Architectural Consultant & Engineers
 Nilesh V. Bhatt
 Engineer
 Scale: 1:100
 Date: 05/05/2024
 Street No: 1

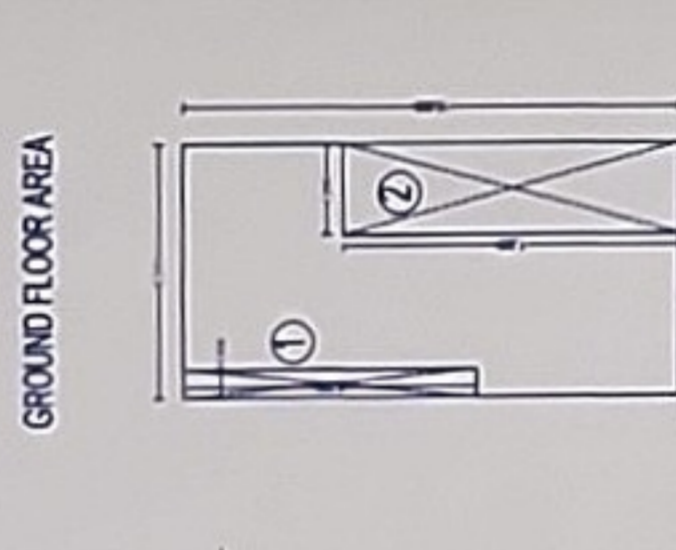
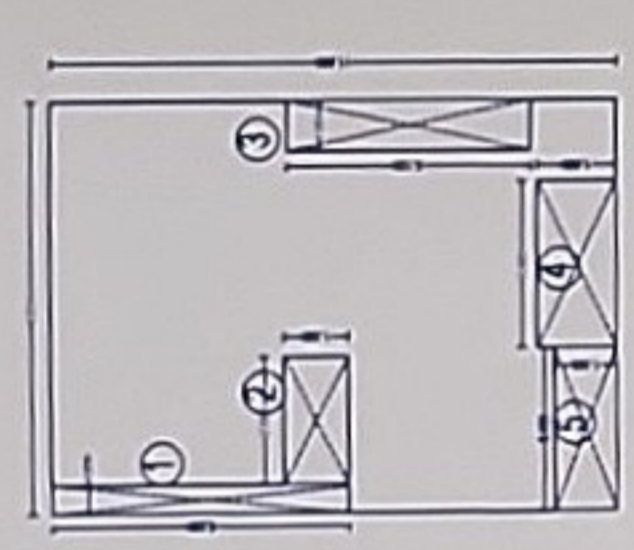
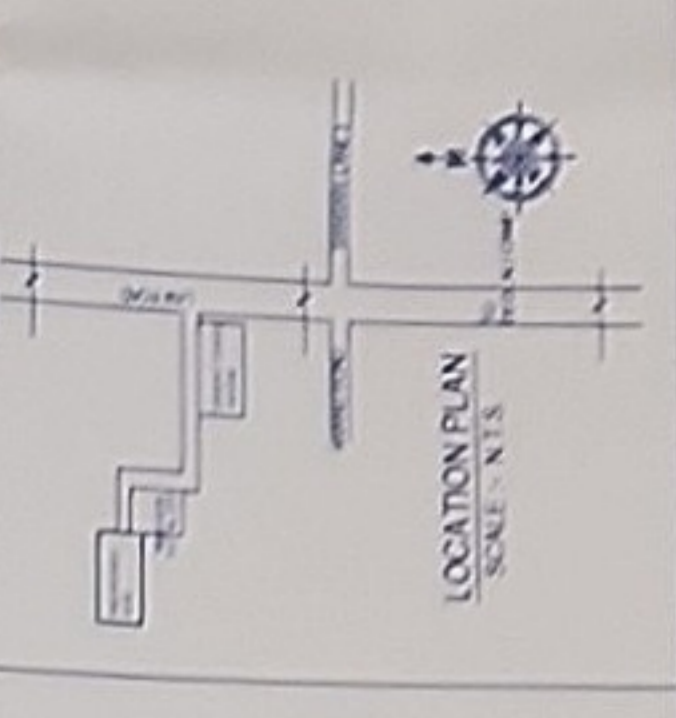
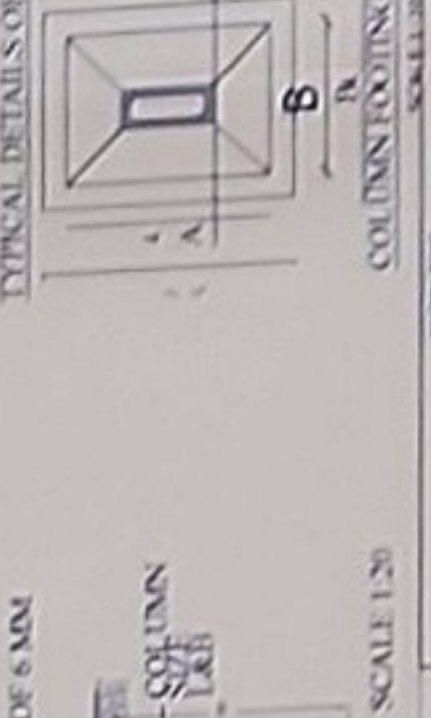
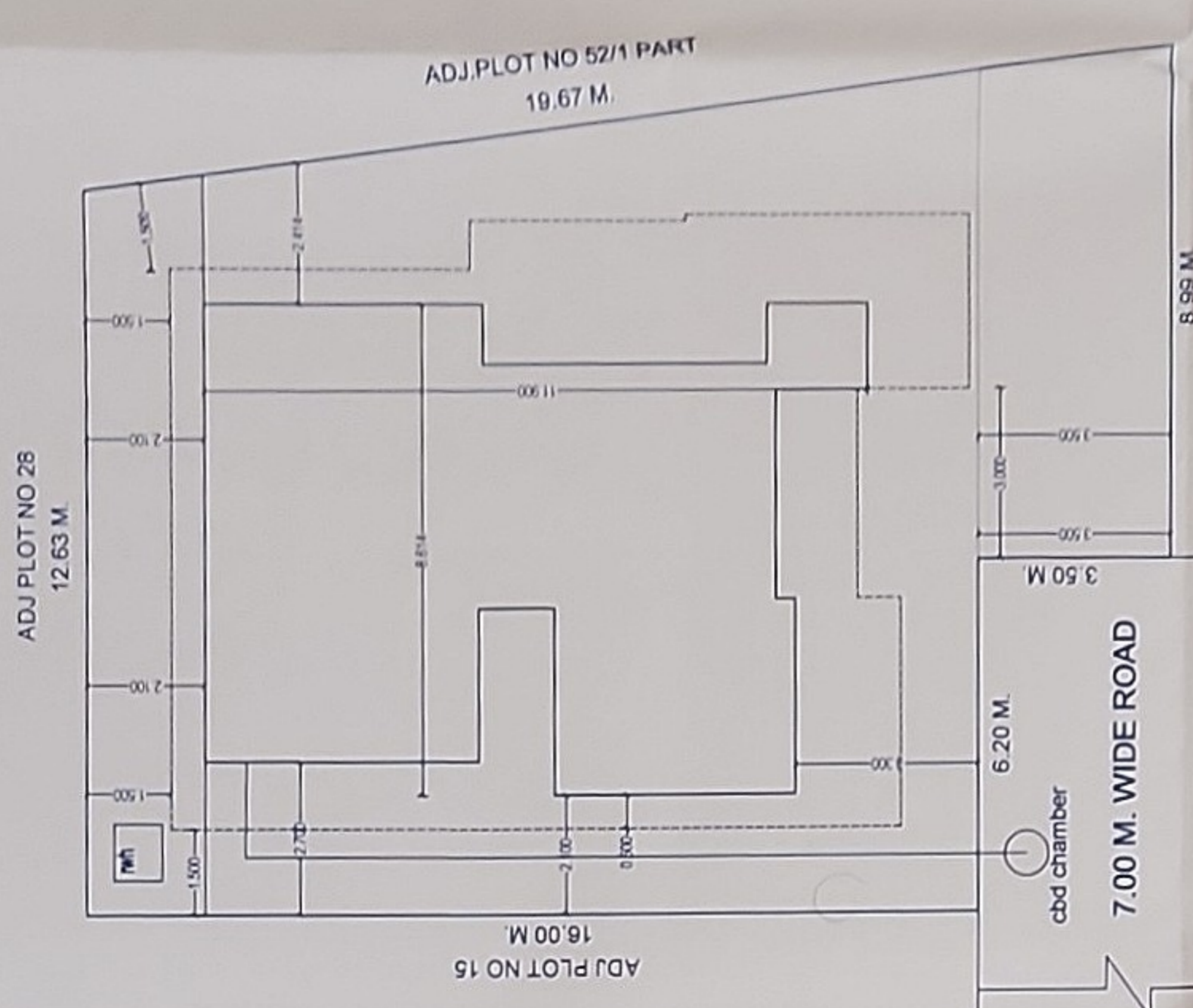

Block	deduction	Area	Total
1	0.66	6.25	3.750
2	2.683	1.35	3.622
3	1.051	5.12	5.381
4	3.403	1.65	5.763
5	3.433	1.3	4.463
Total	102.507	22.98	79.527

Block	deduction	Area	Total
1	0.6	6.25	3.750
2	1.908	7.2	13.738
Total	56.615	17.488	39.127

Total	79.527	39.127	118.654
--------------	---------------	---------------	----------------

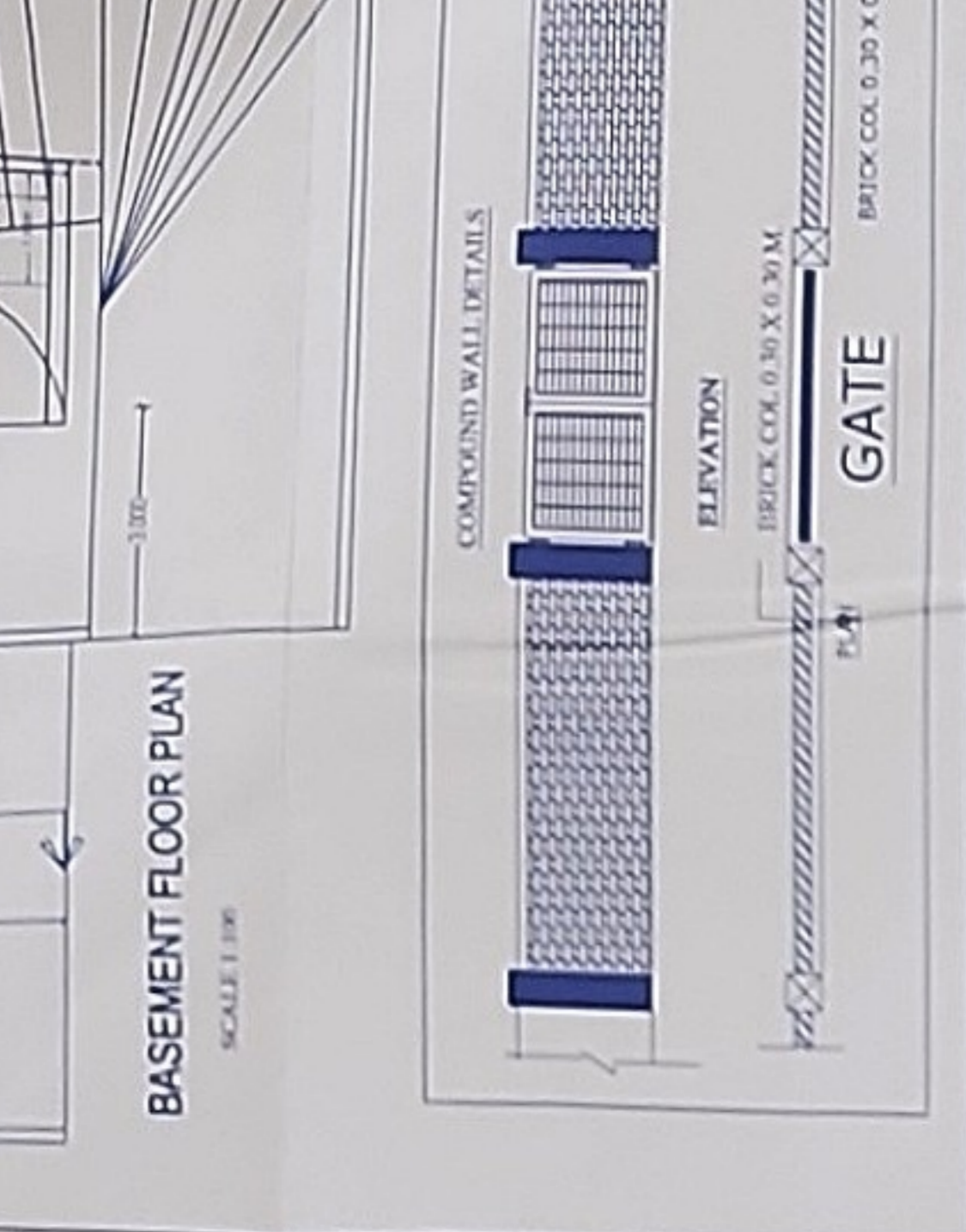
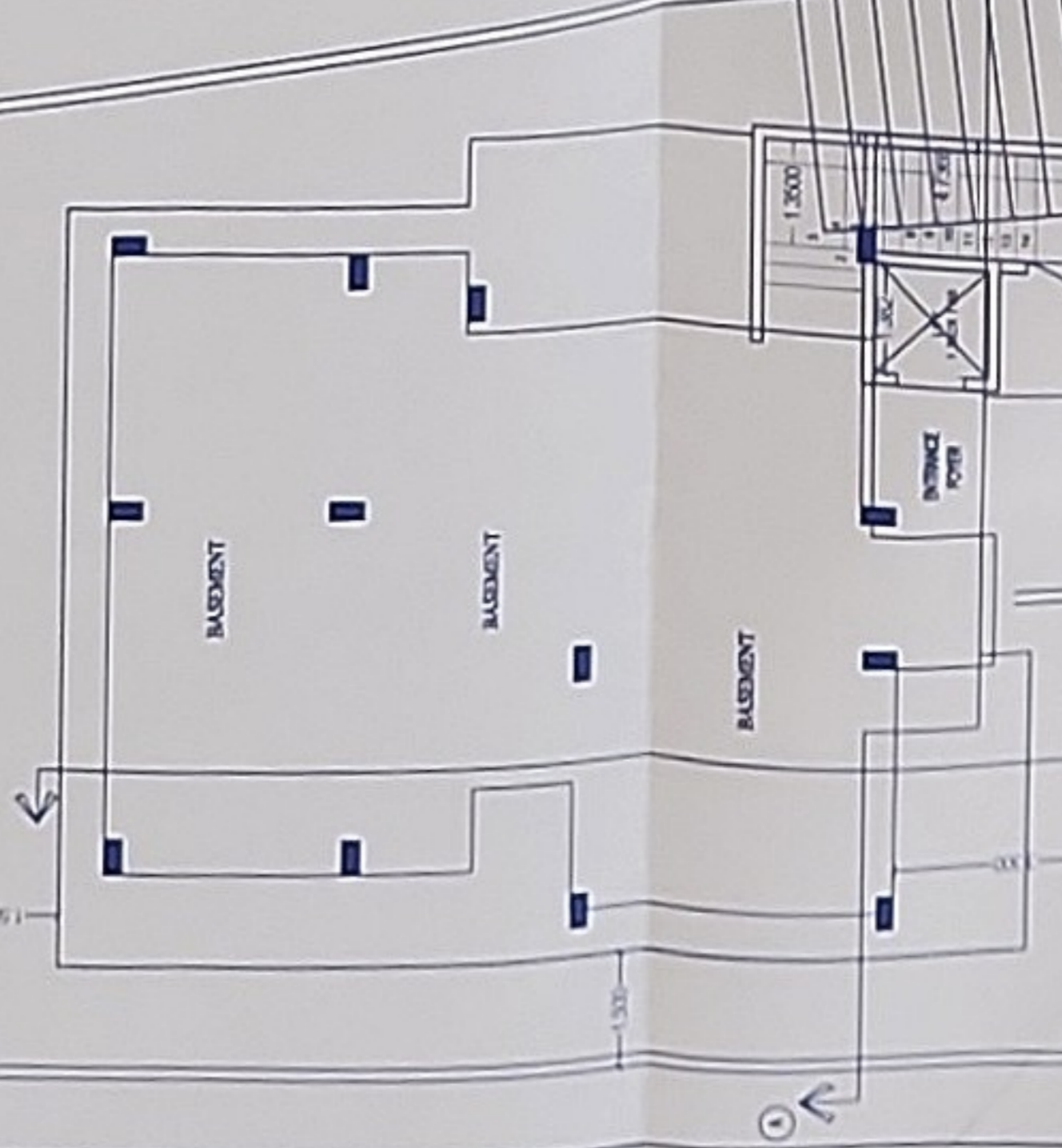
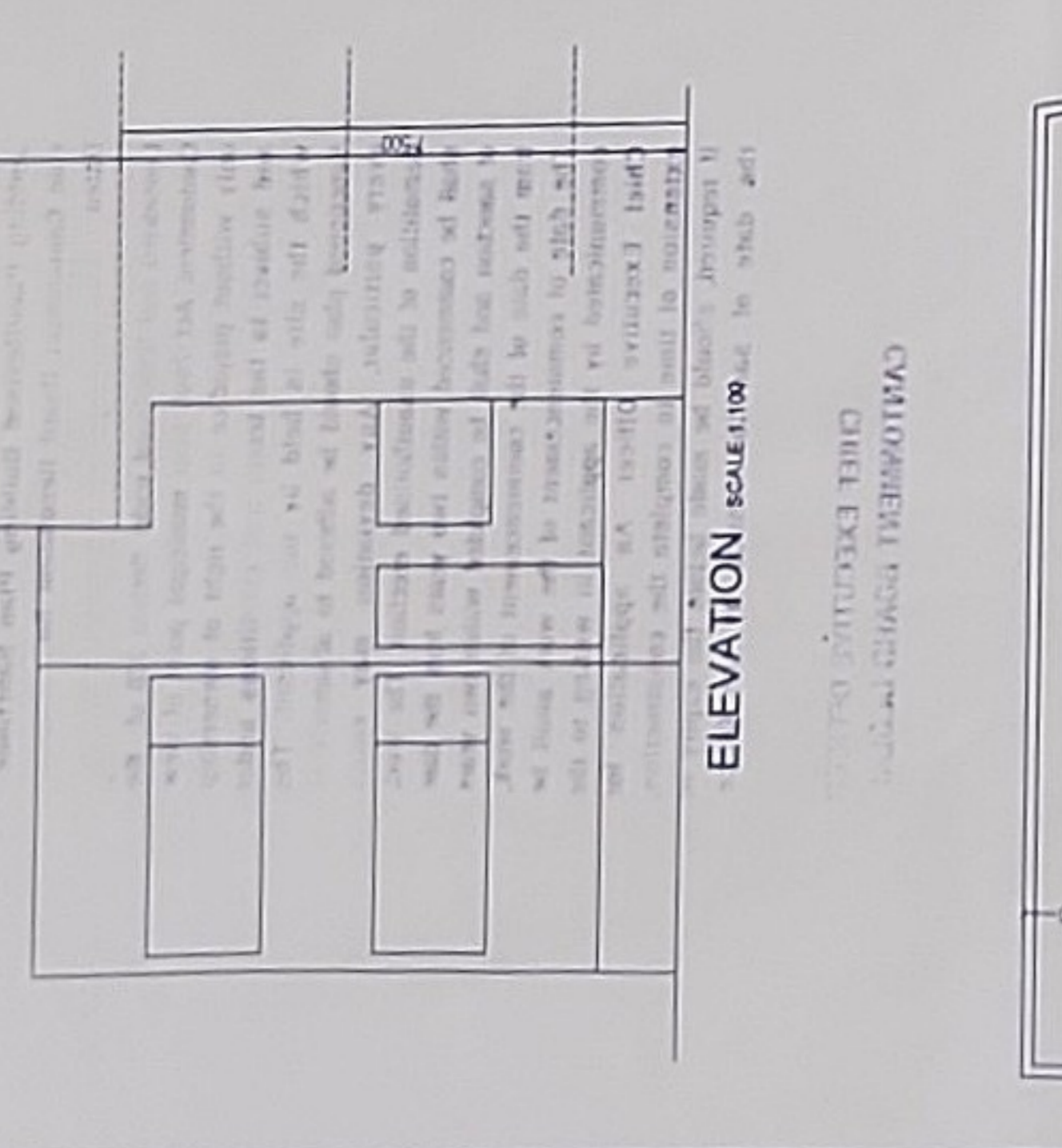
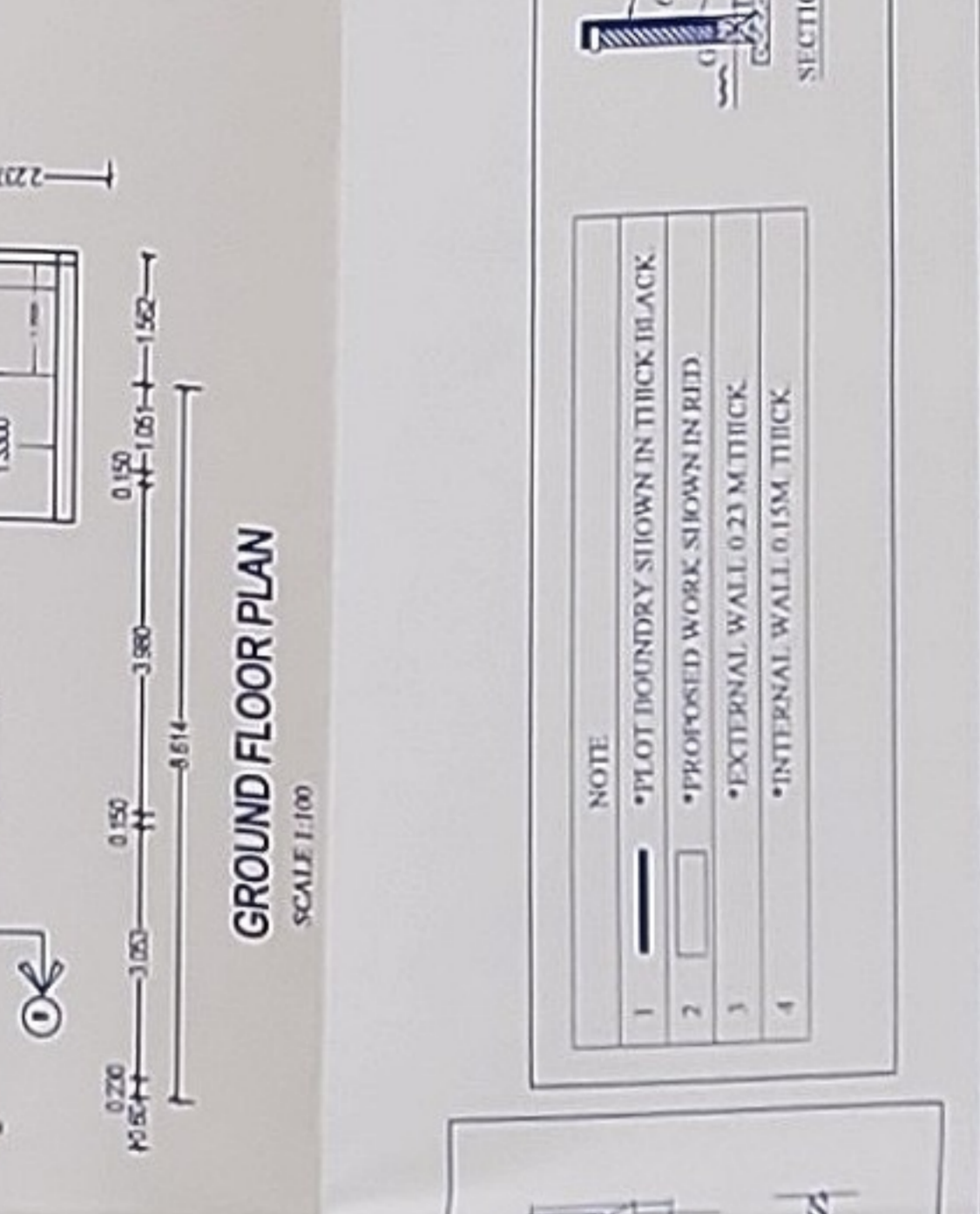
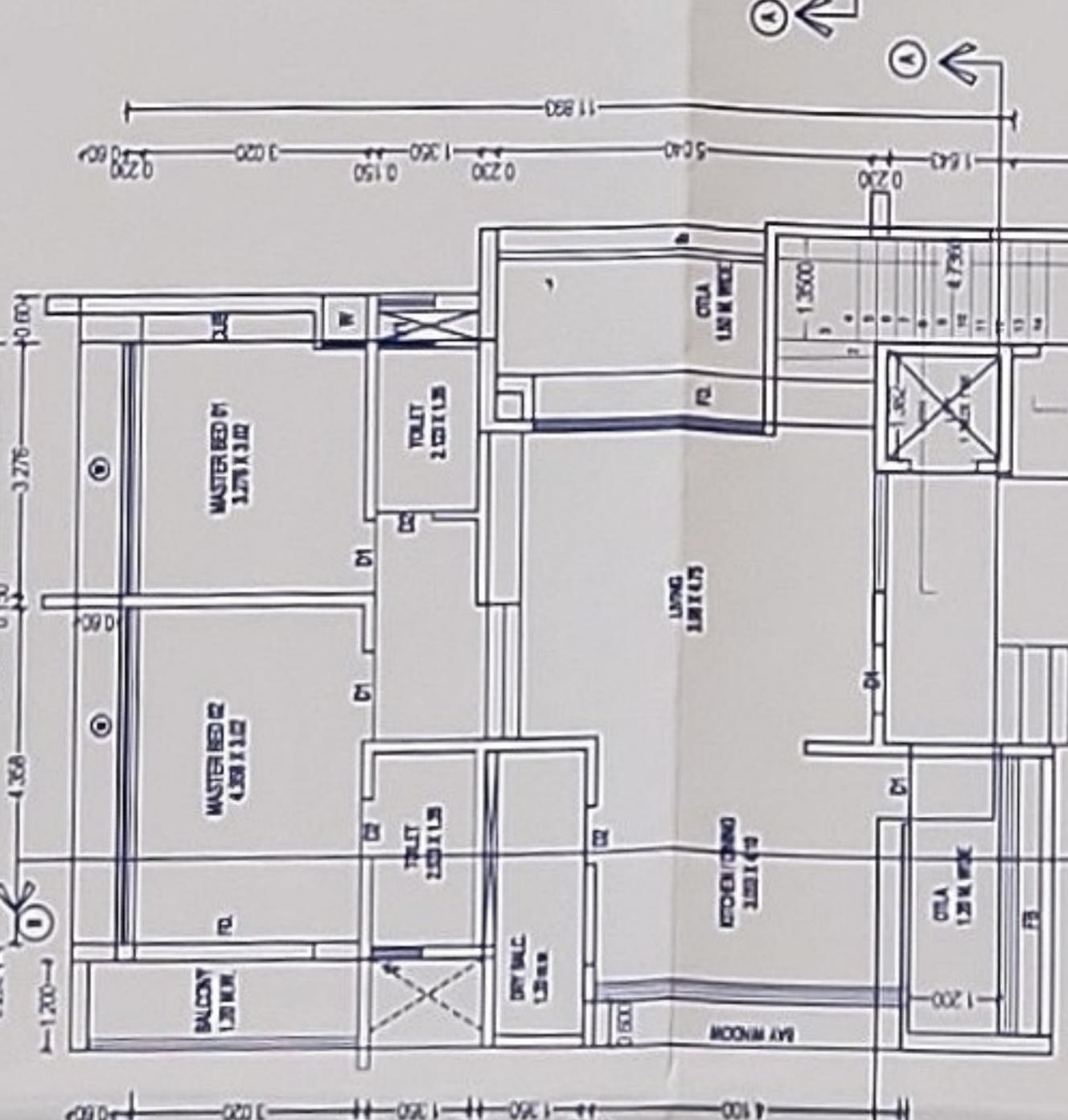
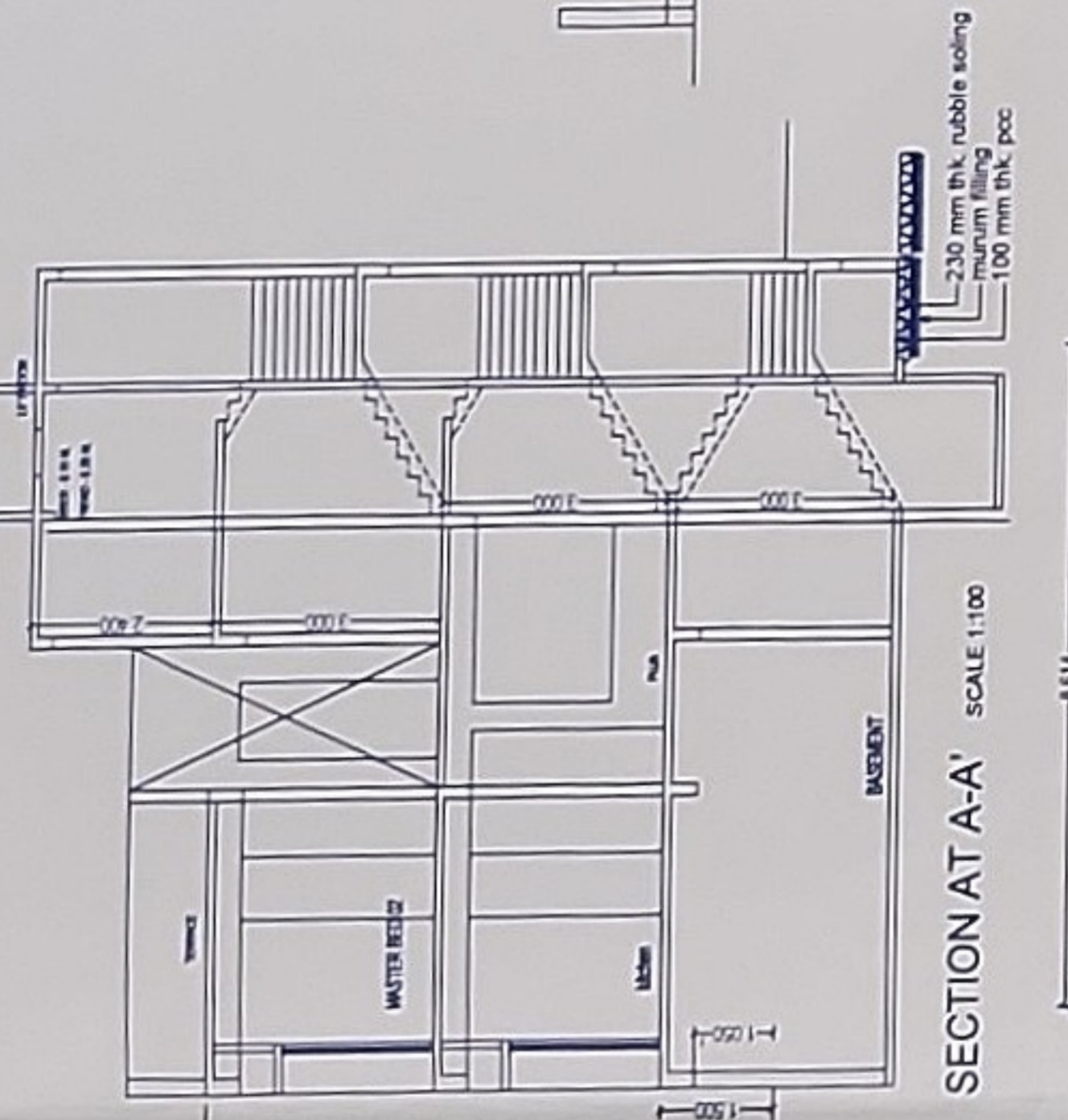
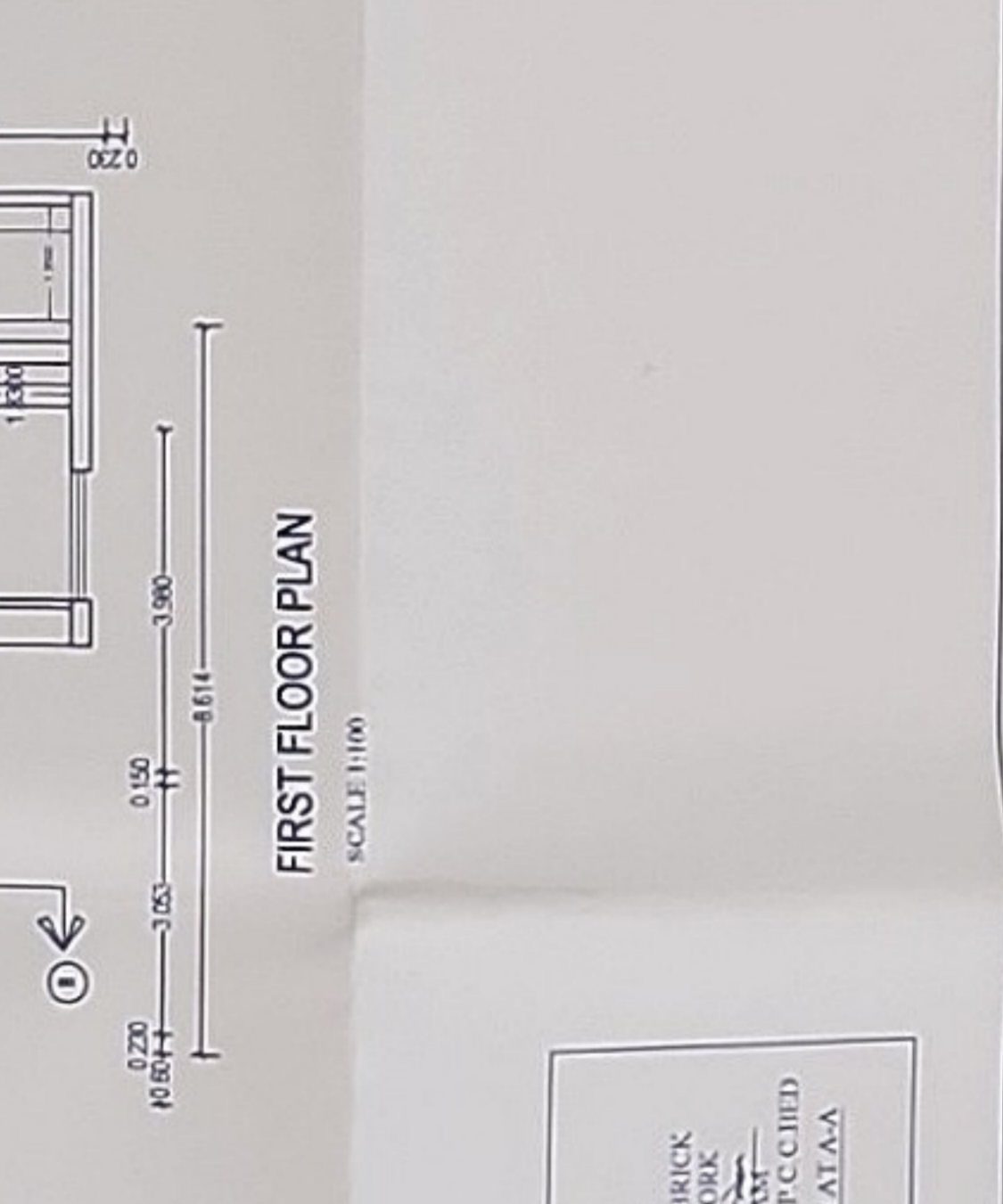
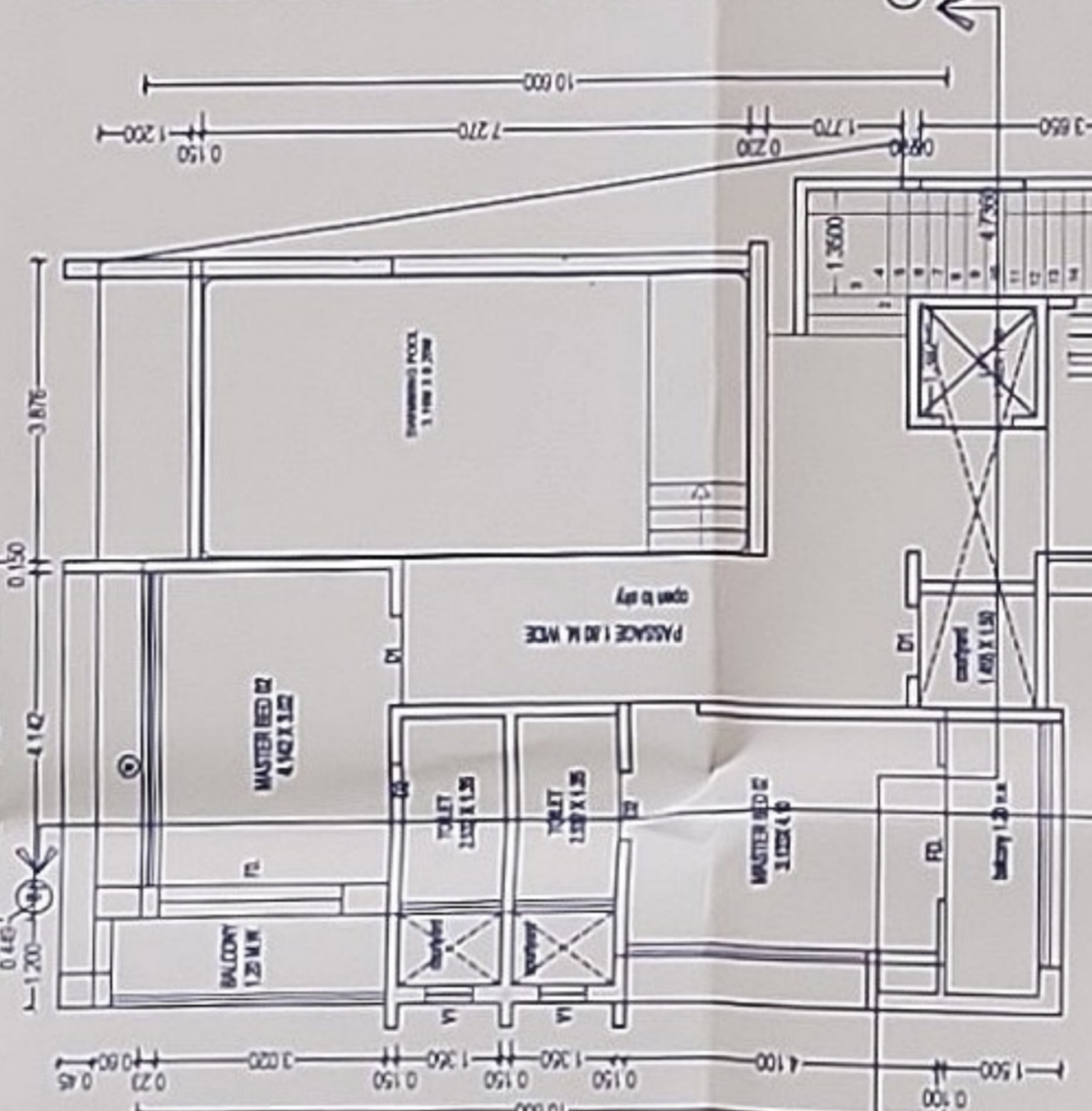
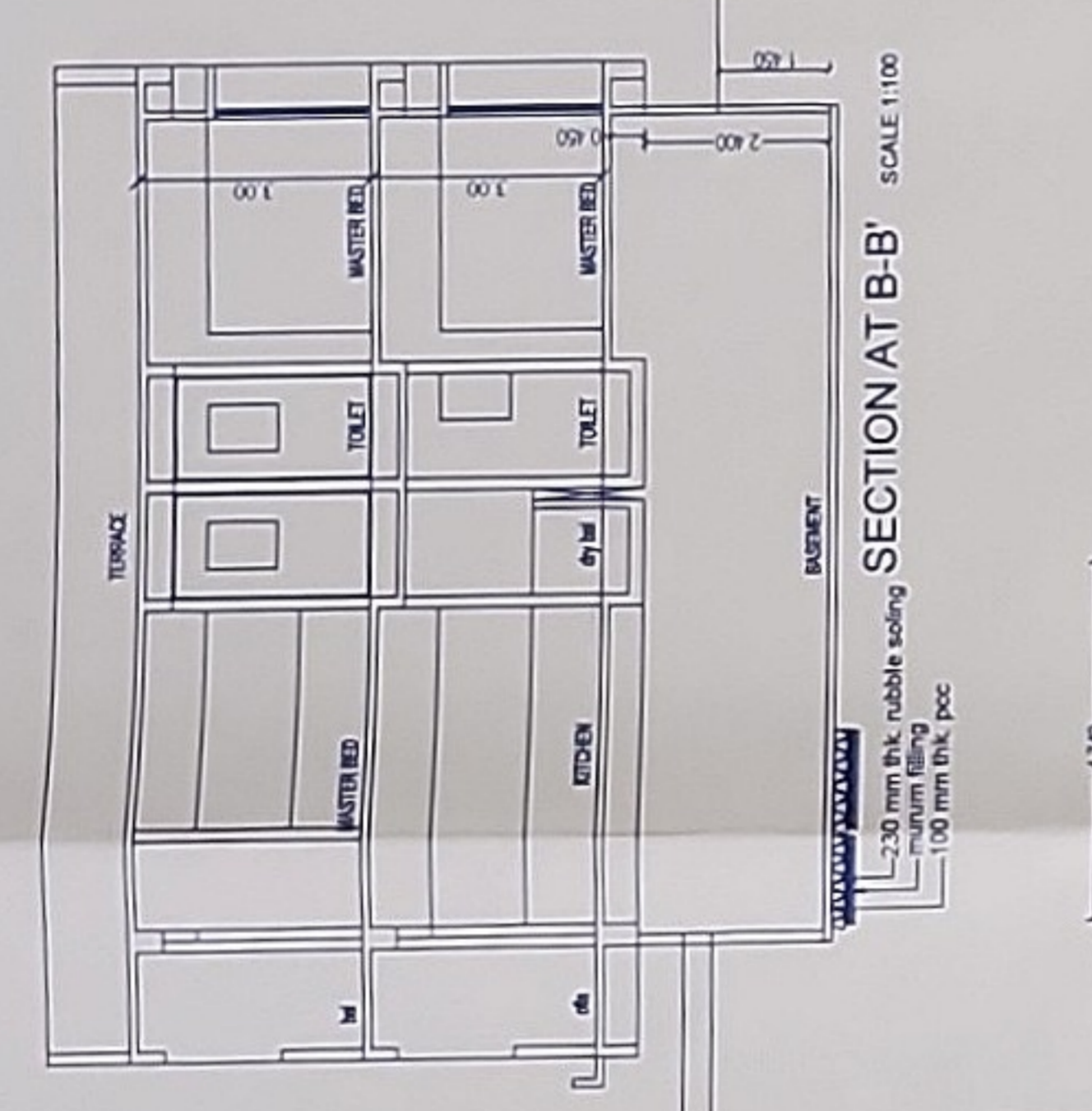
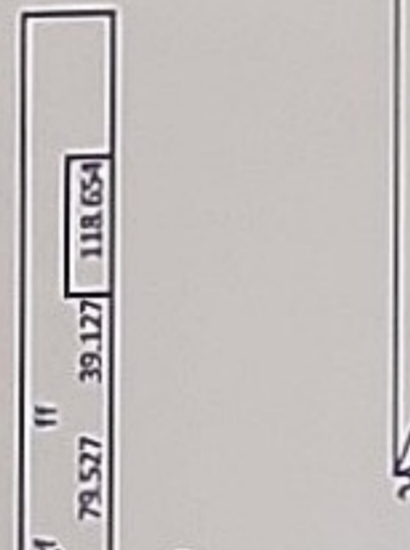

CHALLOMBAI POWER WORKS
 CHIEF EXECUTIVE OFFICER