

CONSTANCE - BLOCK PLAN FLOOR PLAN SECTION DRAWING
BUILT UP CALCULATION

OFFICE OF THE KALYANDOMVENJI MUNICIPAL CORPORATION, KALYAN.

Building Permit No.: KDMCC/TPB/2022/11149c/2022-23/02
Date: 13/04/2022

RECEIVED
SANCTIONED



ASSISTANT DIRECTOR OF TOWN PLANNING
Kalyan-Dombivli Municipal Corporation

Table with 3 columns: AREA STATEMENT, Details (a-f), and SQA. Rows include items like 'Area of plot', 'Area of built-up area', 'Area reserved for open spaces', etc.

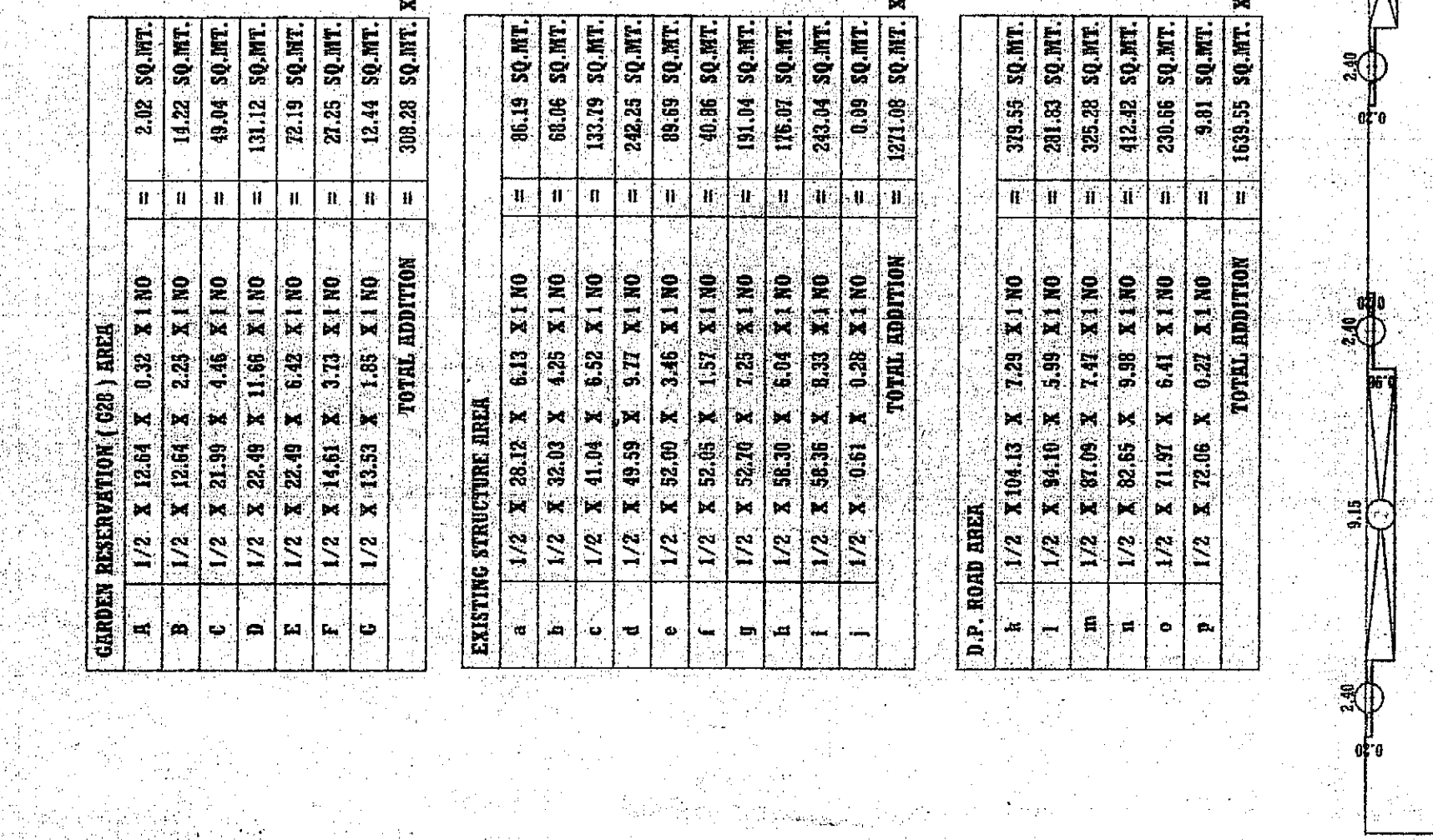
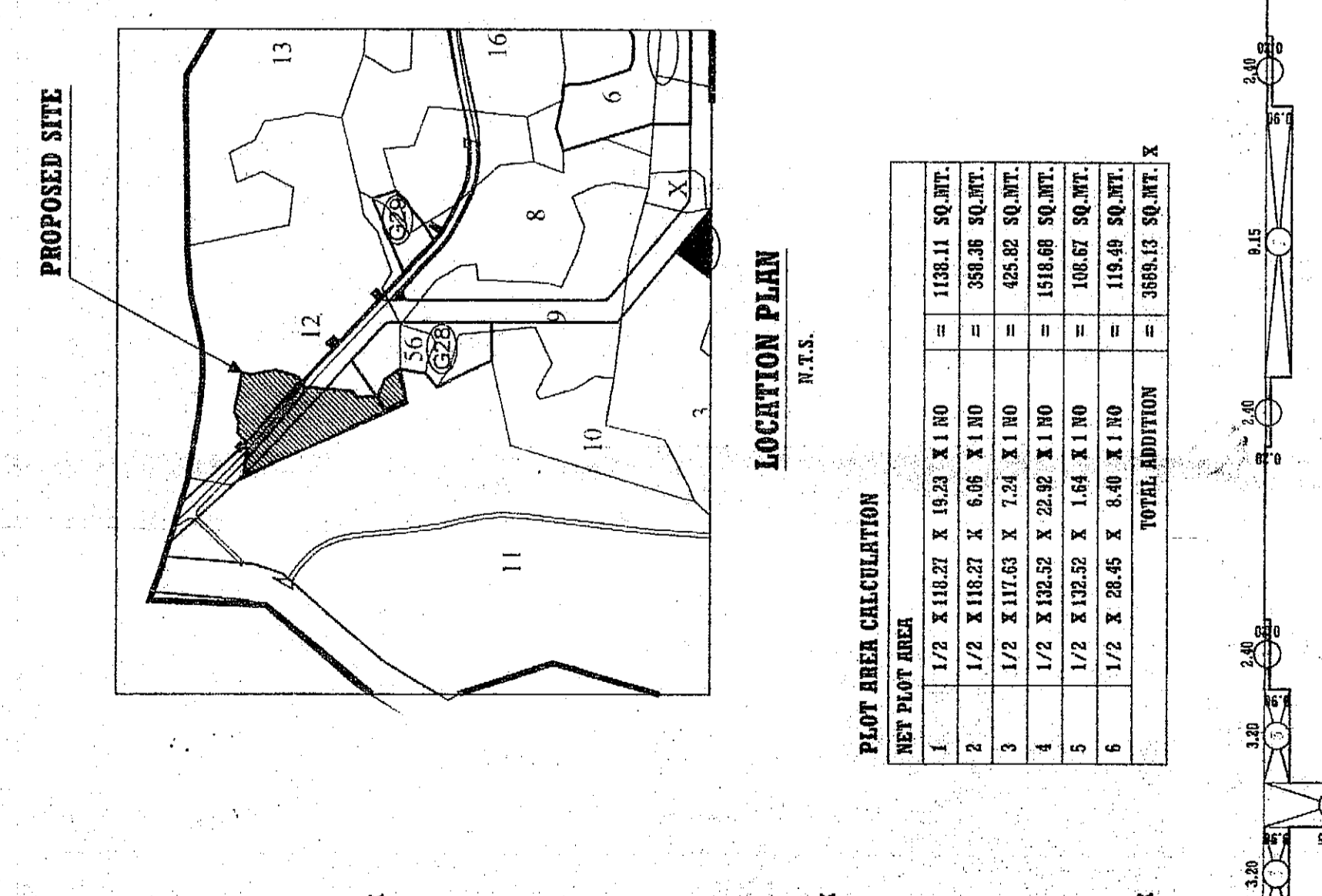
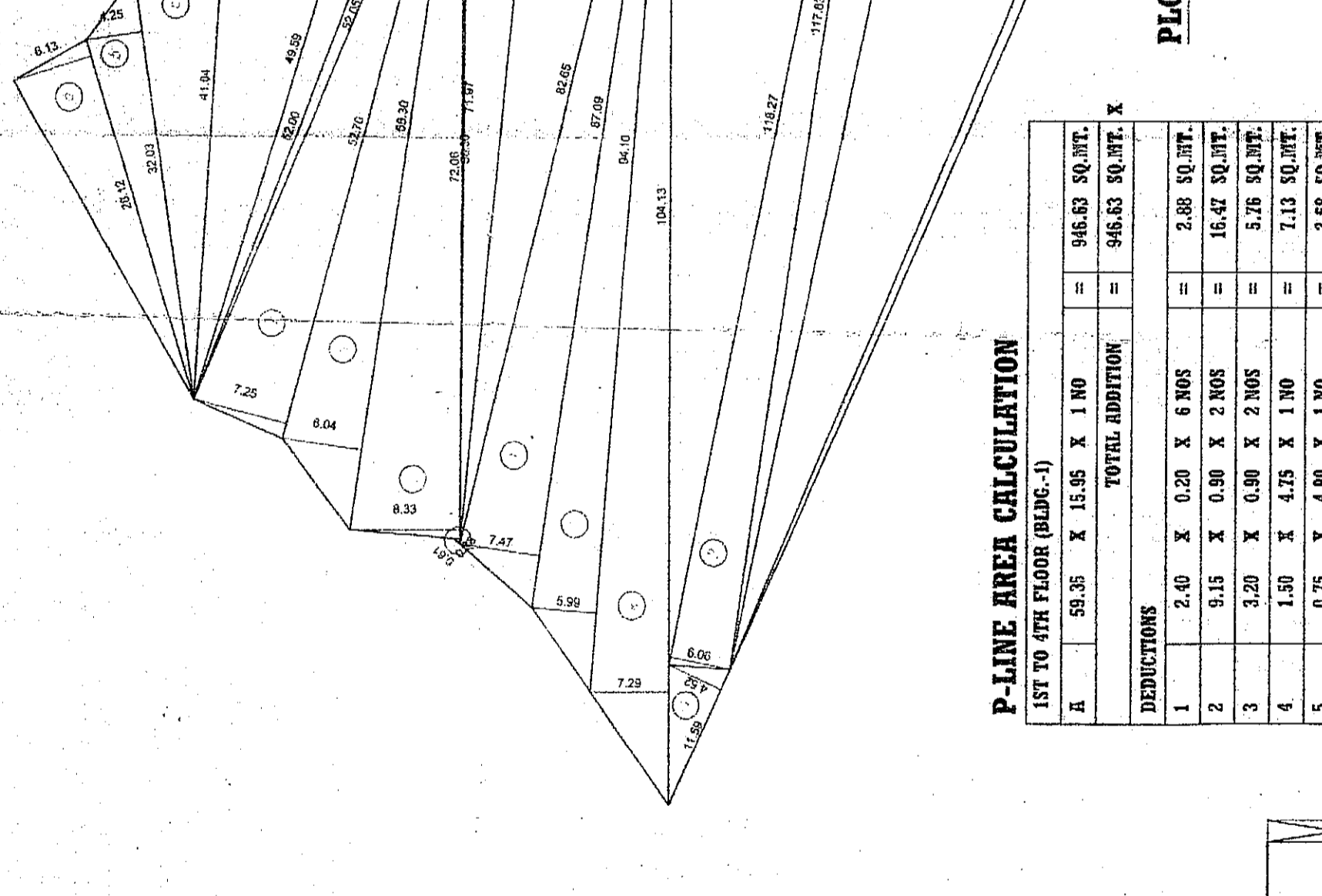
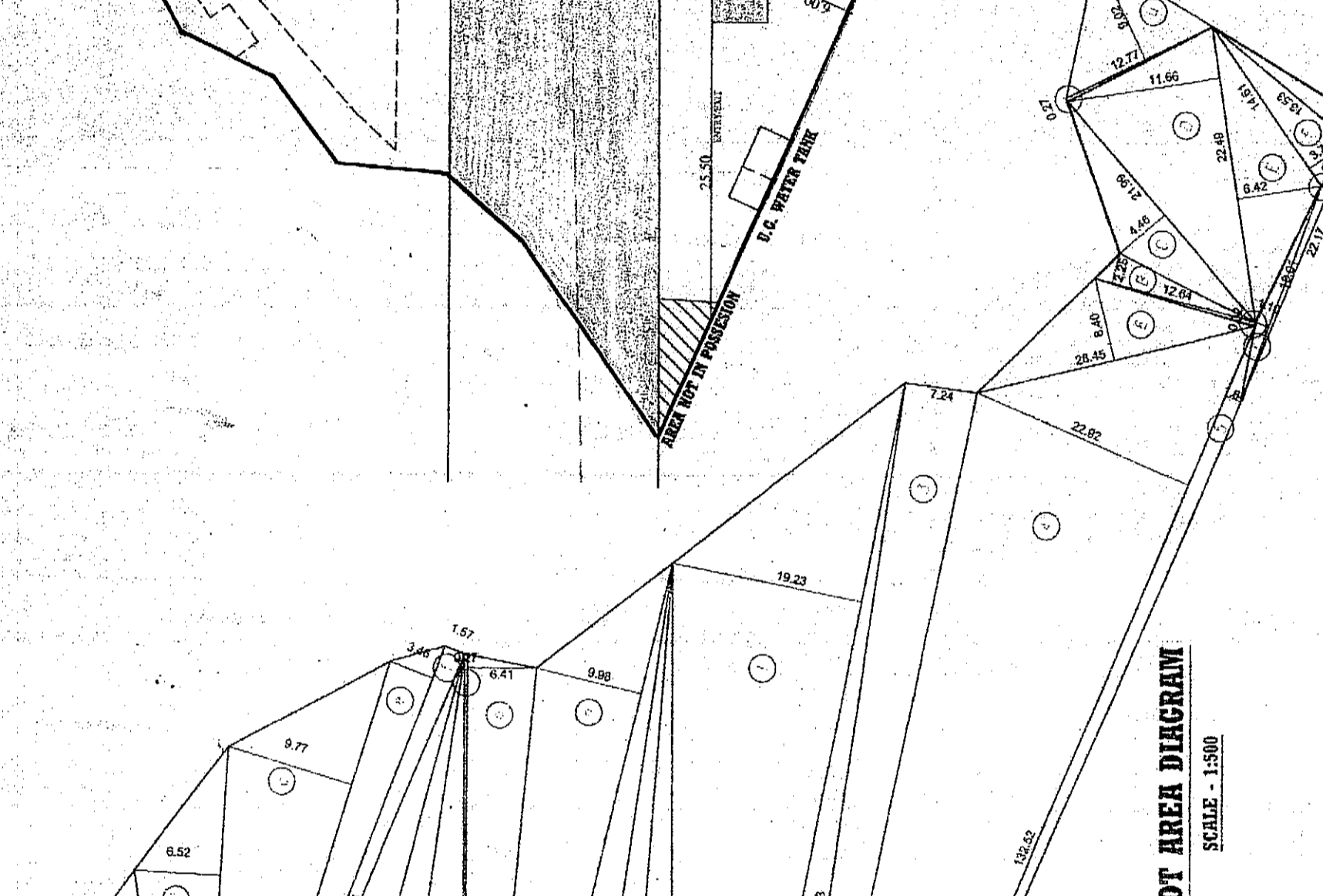
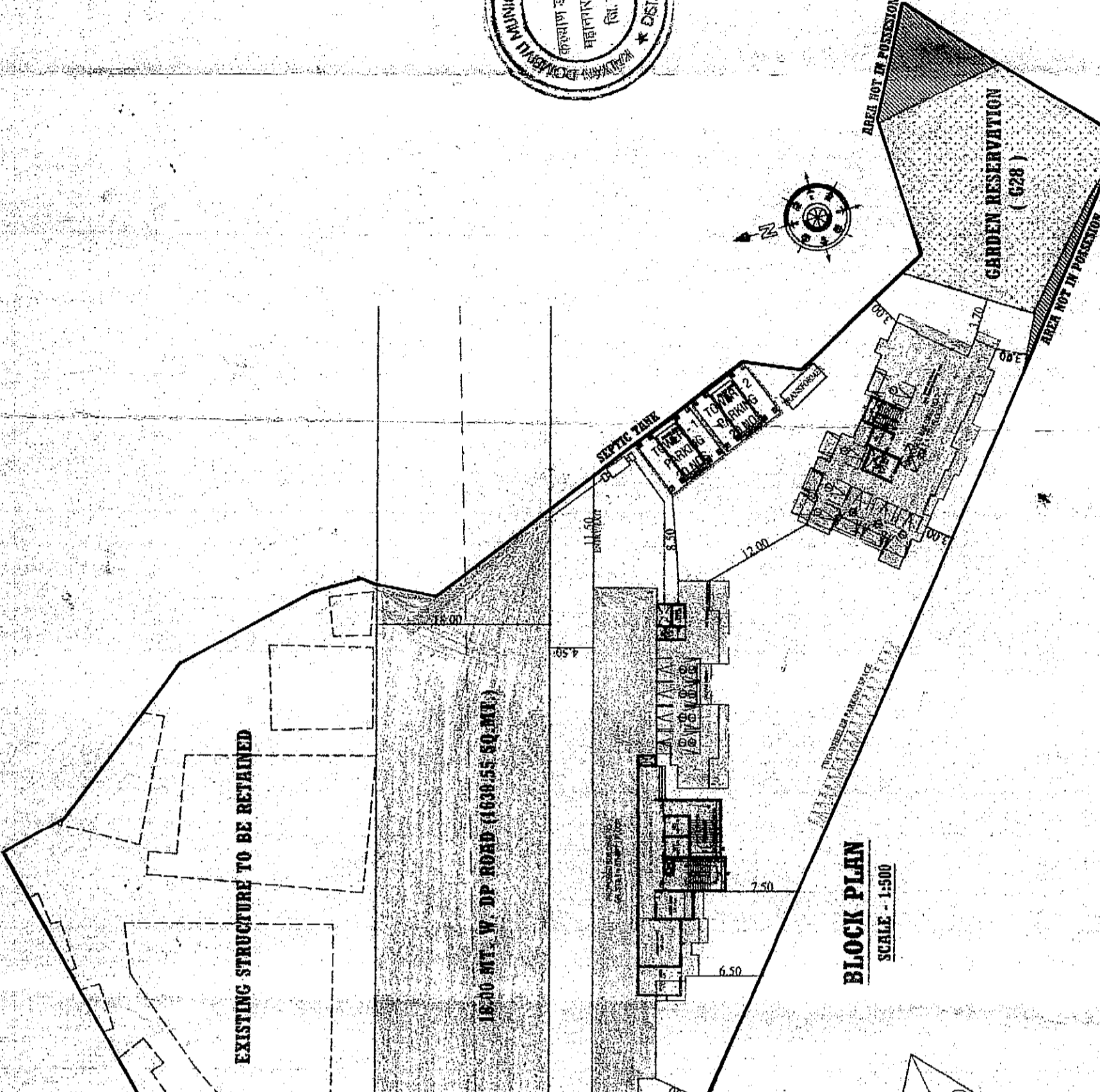

Table titled 'PROPOSED BUILDING' with columns for Building No., Floor No., and Total Built-up Area of Floor. It lists buildings BLDG-1, BLDG-2, and BLDG-3 across various floors.

Table titled 'P-LINE AREA STATEMENT (BLDG. NO. 1)' showing the area of each floor (Ground to 10th) and the total area.

Table titled 'P-LINE AREA STATEMENT (BLDG. NO. 2)' showing the area of each floor (Ground to 10th) and the total area.

Table titled 'P-LINE AREA STATEMENT (BLDG. NO. 3)' showing the area of each floor (Ground to 10th) and the total area.

Table titled 'P-LINE AREA STATEMENT (BLDG. NO. 4)' showing the area of each floor (Ground to 10th) and the total area.

Table titled 'P-LINE AREA STATEMENT (BLDG. NO. 5)' showing the area of each floor (Ground to 10th) and the total area.

Table titled 'P-LINE AREA STATEMENT (BLDG. NO. 6)' showing the area of each floor (Ground to 10th) and the total area.

Table titled 'P-LINE AREA STATEMENT (BLDG. NO. 7)' showing the area of each floor (Ground to 10th) and the total area.

Table titled 'P-LINE AREA STATEMENT (BLDG. NO. 8)' showing the area of each floor (Ground to 10th) and the total area.

Table titled 'P-LINE AREA STATEMENT (BLDG. NO. 9)' showing the area of each floor (Ground to 10th) and the total area.

Table titled 'P-LINE AREA STATEMENT (BLDG. NO. 10)' showing the area of each floor (Ground to 10th) and the total area.

Table titled 'P-LINE AREA STATEMENT (BLDG. NO. 11)' showing the area of each floor (Ground to 10th) and the total area.

Table titled 'P-LINE AREA STATEMENT (BLDG. NO. 12)' showing the area of each floor (Ground to 10th) and the total area.

Table titled 'P-LINE AREA STATEMENT (BLDG. NO. 13)' showing the area of each floor (Ground to 10th) and the total area.

Table titled 'P-LINE AREA STATEMENT (BLDG. NO. 14)' showing the area of each floor (Ground to 10th) and the total area.

Table titled 'P-LINE AREA STATEMENT (BLDG. NO. 15)' showing the area of each floor (Ground to 10th) and the total area.

Table titled 'P-LINE AREA STATEMENT (BLDG. NO. 16)' showing the area of each floor (Ground to 10th) and the total area.

Table titled 'P-LINE AREA STATEMENT (BLDG. NO. 17)' showing the area of each floor (Ground to 10th) and the total area.

Table titled 'P-LINE AREA STATEMENT (BLDG. NO. 18)' showing the area of each floor (Ground to 10th) and the total area.

Table titled 'P-LINE AREA STATEMENT (BLDG. NO. 19)' showing the area of each floor (Ground to 10th) and the total area.

Table titled 'P-LINE AREA STATEMENT (BLDG. NO. 20)' showing the area of each floor (Ground to 10th) and the total area.

Table titled 'P-LINE AREA STATEMENT (BLDG. NO. 21)' showing the area of each floor (Ground to 10th) and the total area.

Table titled 'P-LINE AREA STATEMENT (BLDG. NO. 22)' showing the area of each floor (Ground to 10th) and the total area.

Table titled 'P-LINE AREA STATEMENT (BLDG. NO. 23)' showing the area of each floor (Ground to 10th) and the total area.

Table titled 'P-LINE AREA STATEMENT (BLDG. NO. 24)' showing the area of each floor (Ground to 10th) and the total area.

Table titled 'P-LINE AREA STATEMENT (BLDG. NO. 25)' showing the area of each floor (Ground to 10th) and the total area.

Table titled 'P-LINE AREA STATEMENT (BLDG. NO. 26)' showing the area of each floor (Ground to 10th) and the total area.

Table titled 'P-LINE AREA STATEMENT (BLDG. NO. 27)' showing the area of each floor (Ground to 10th) and the total area.

Table titled 'P-LINE AREA STATEMENT (BLDG. NO. 28)' showing the area of each floor (Ground to 10th) and the total area.

Table titled 'P-LINE AREA STATEMENT (BLDG. NO. 29)' showing the area of each floor (Ground to 10th) and the total area.

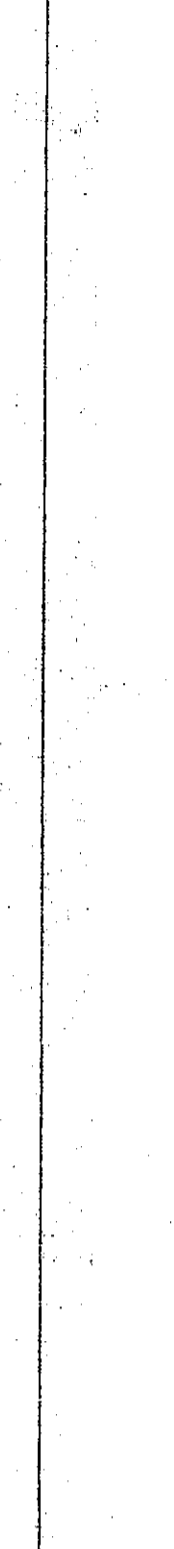
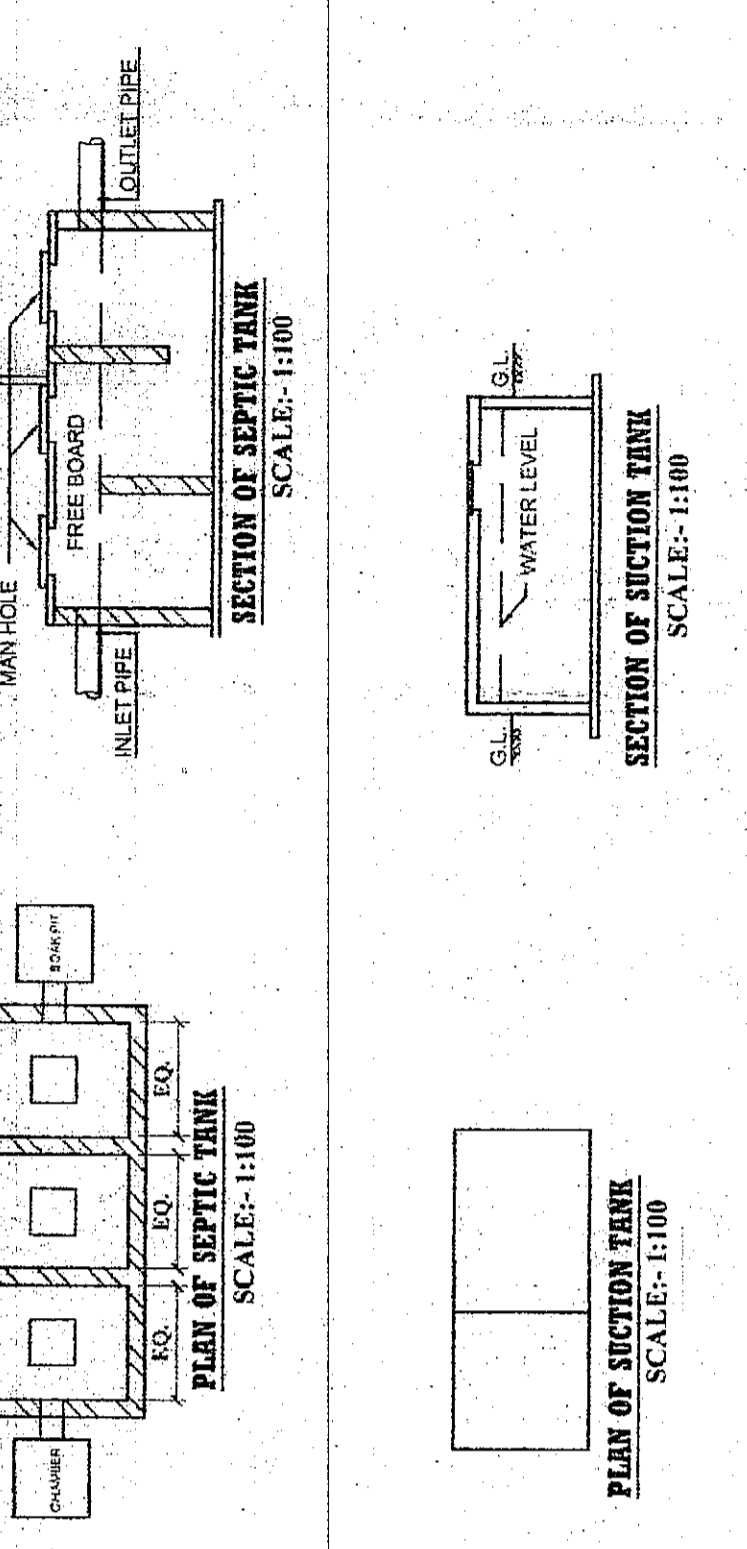
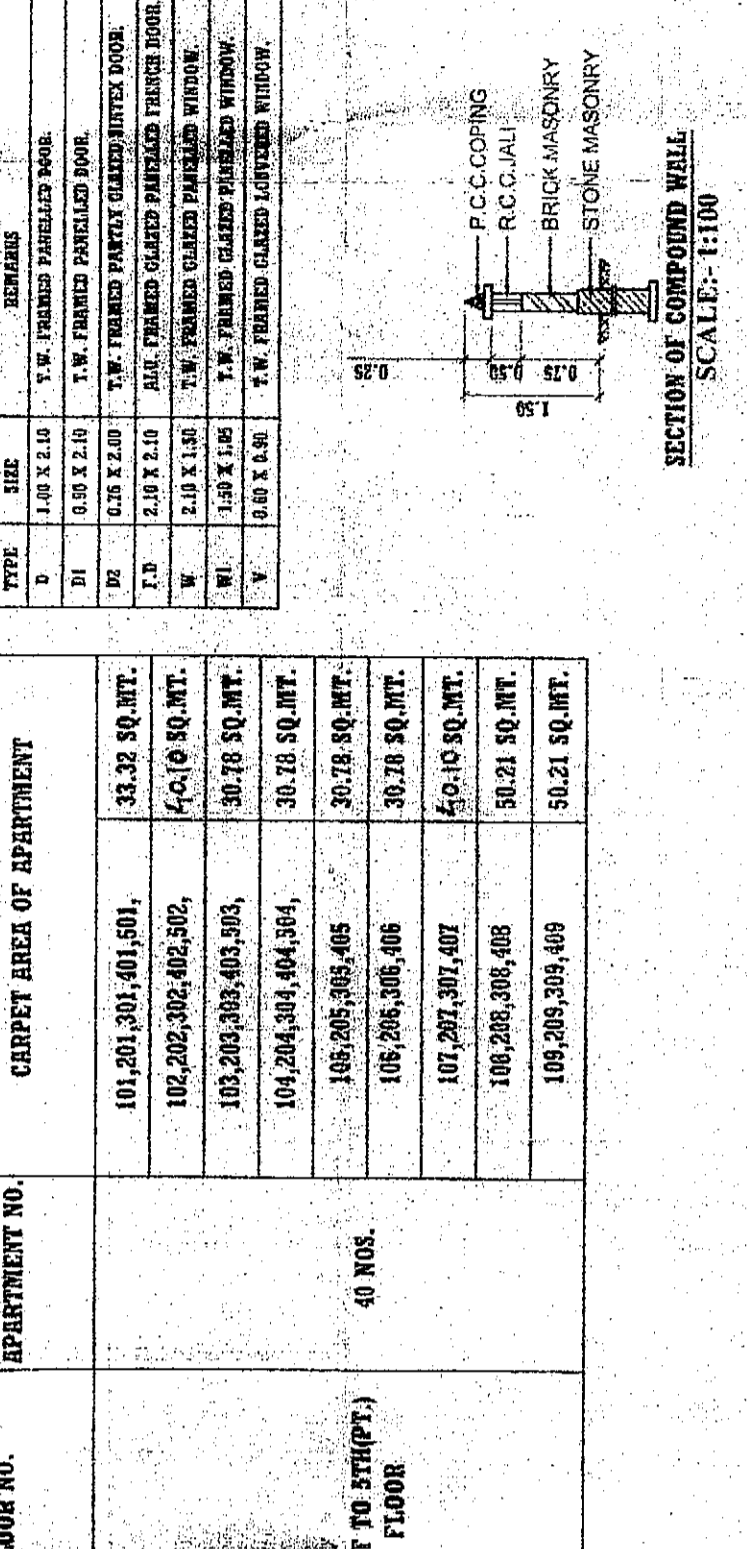
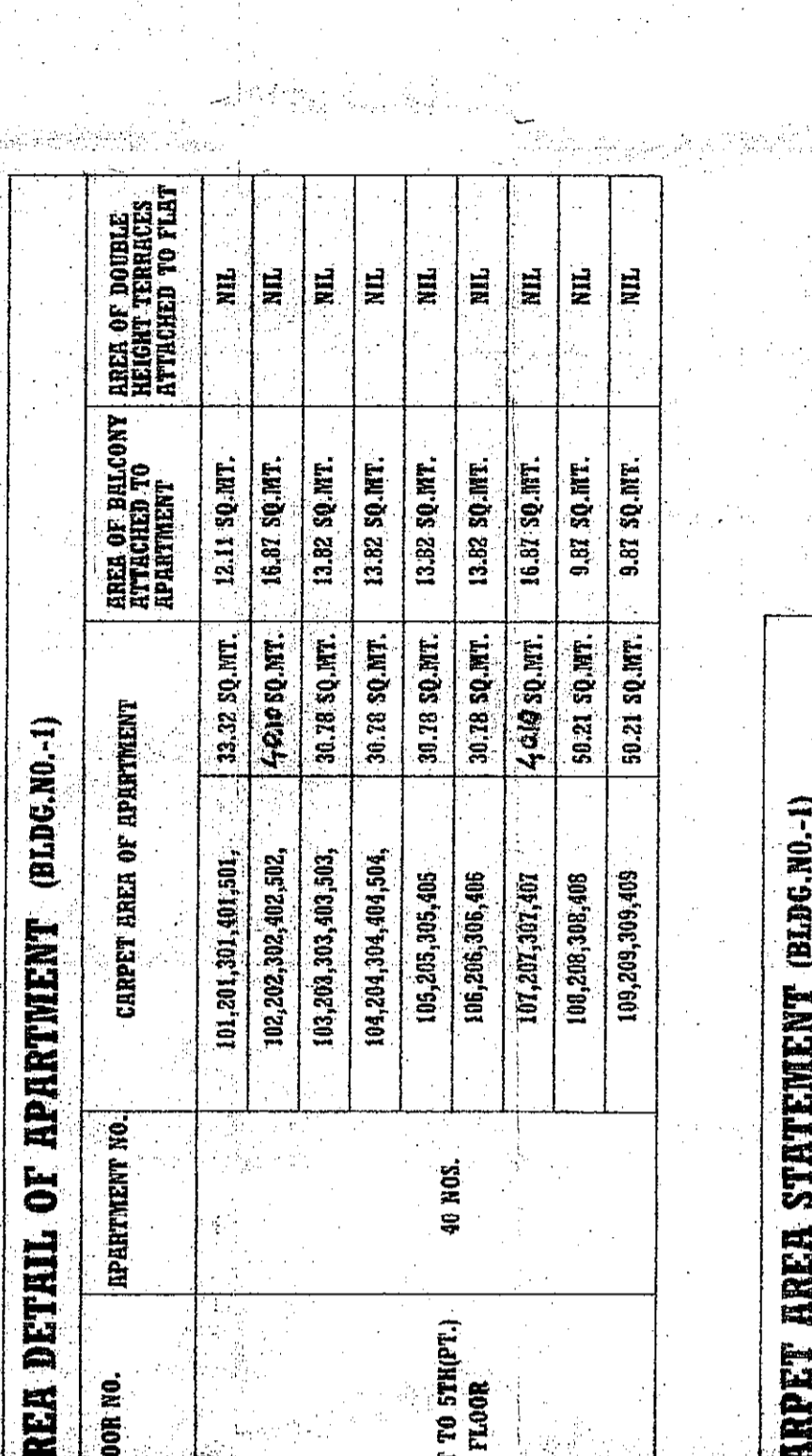
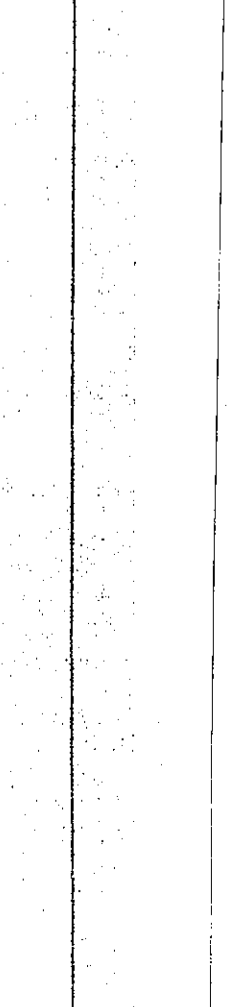
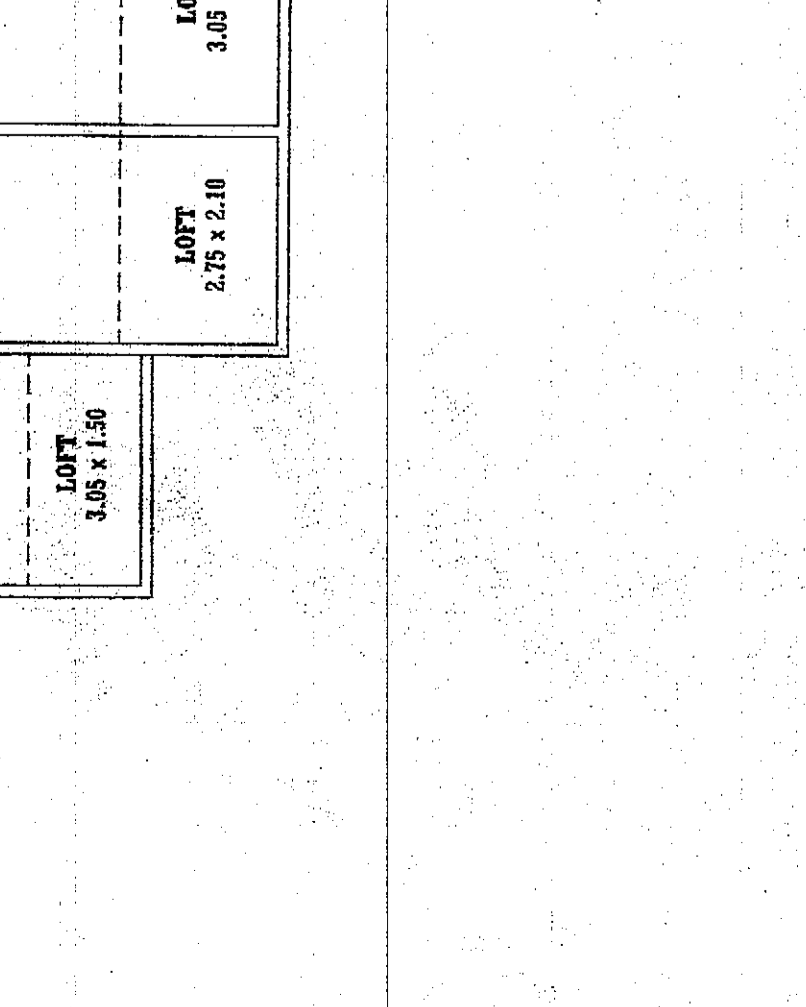
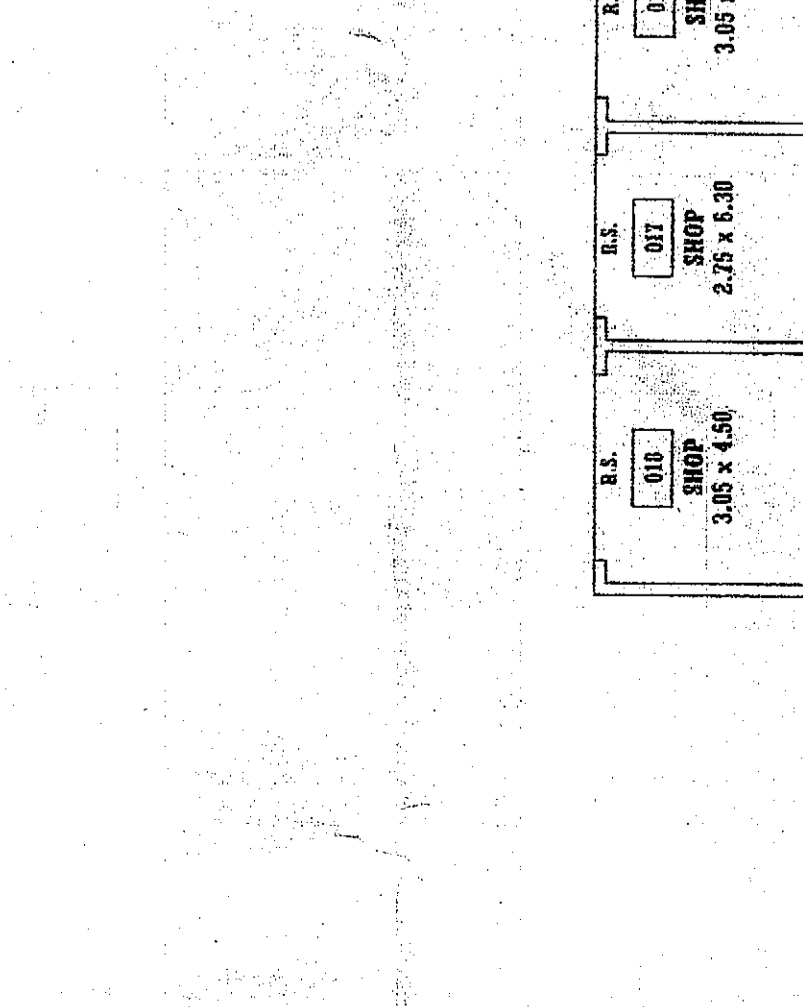
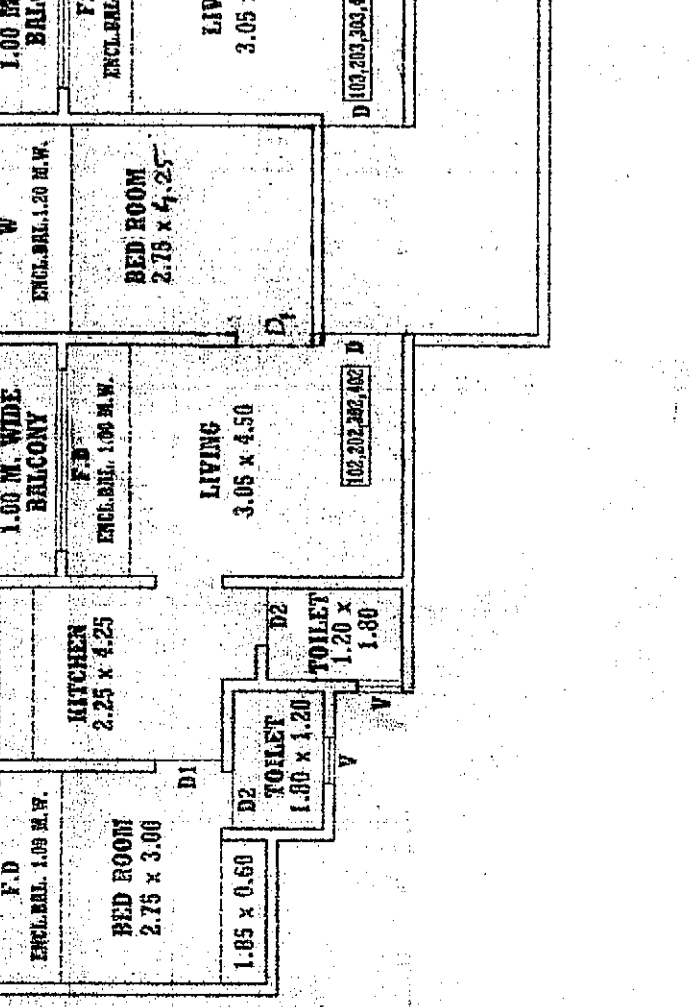
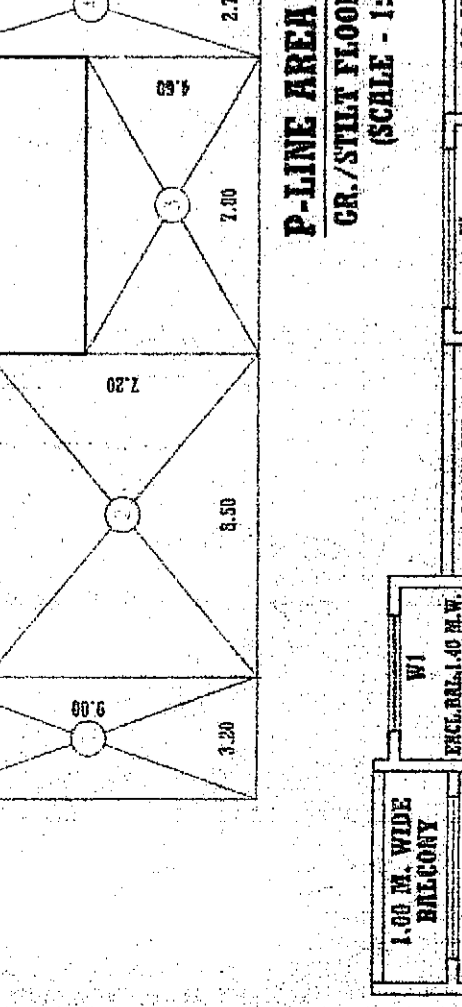
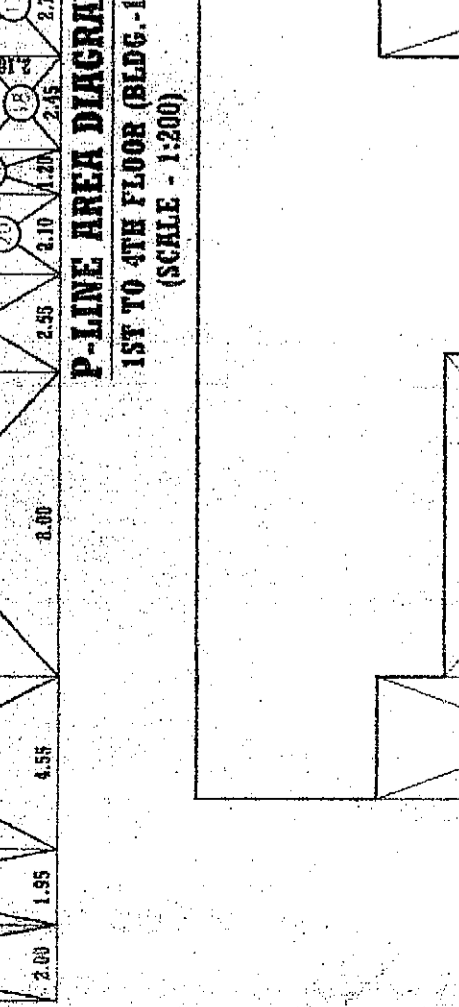
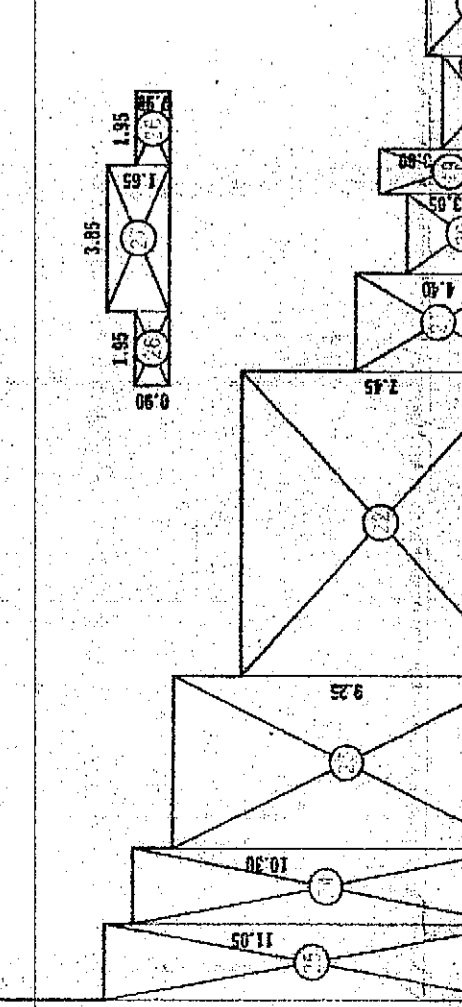
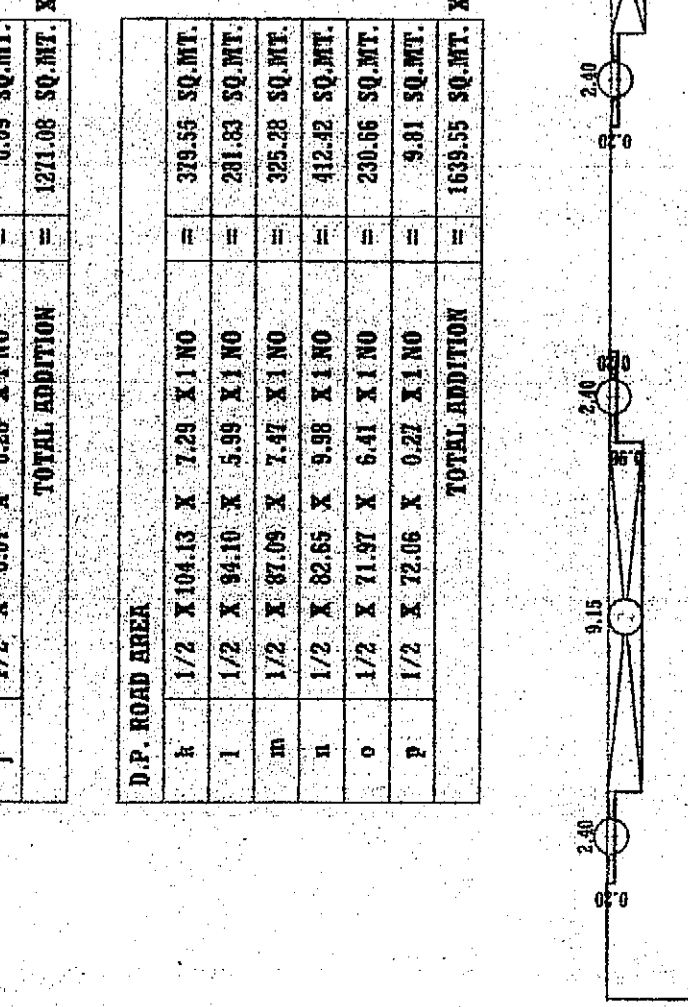
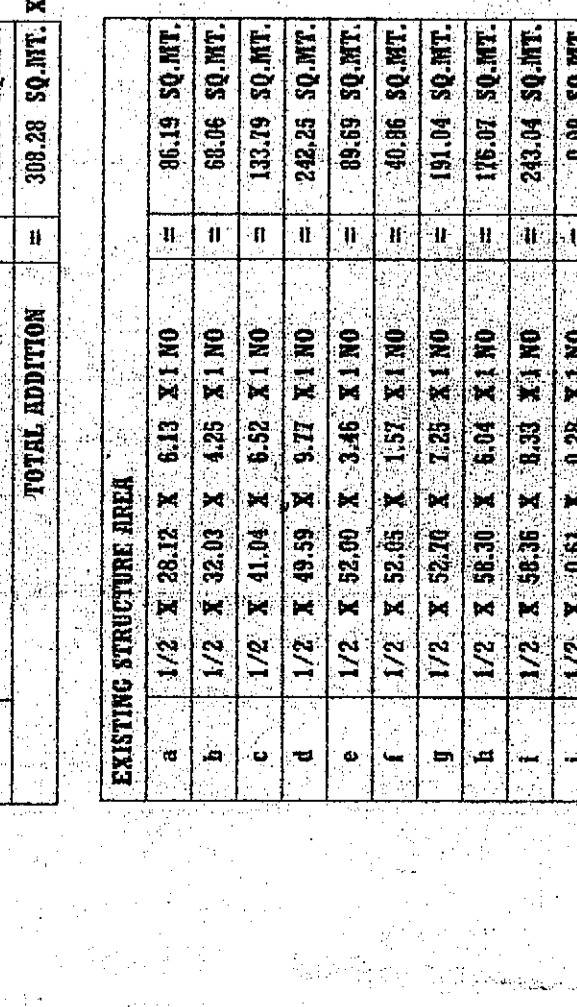
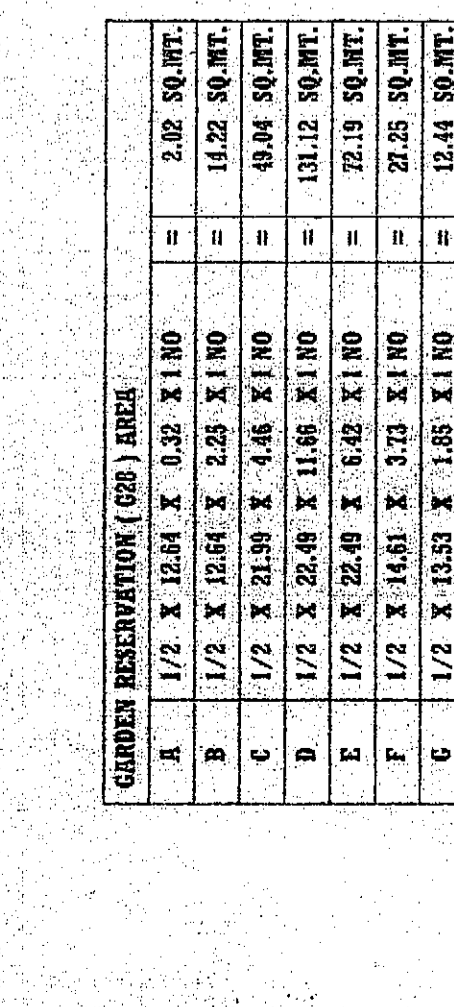
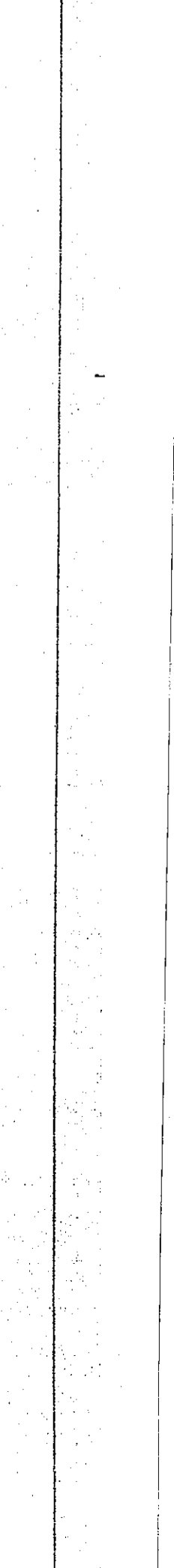
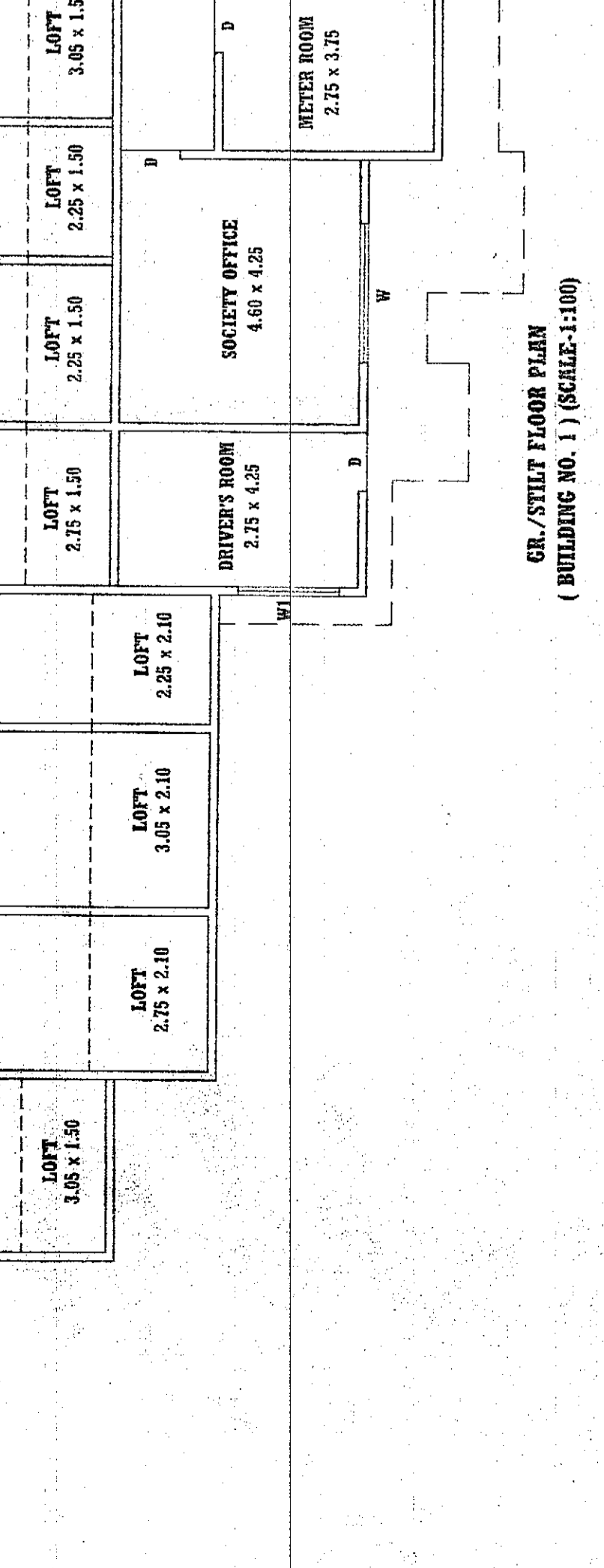
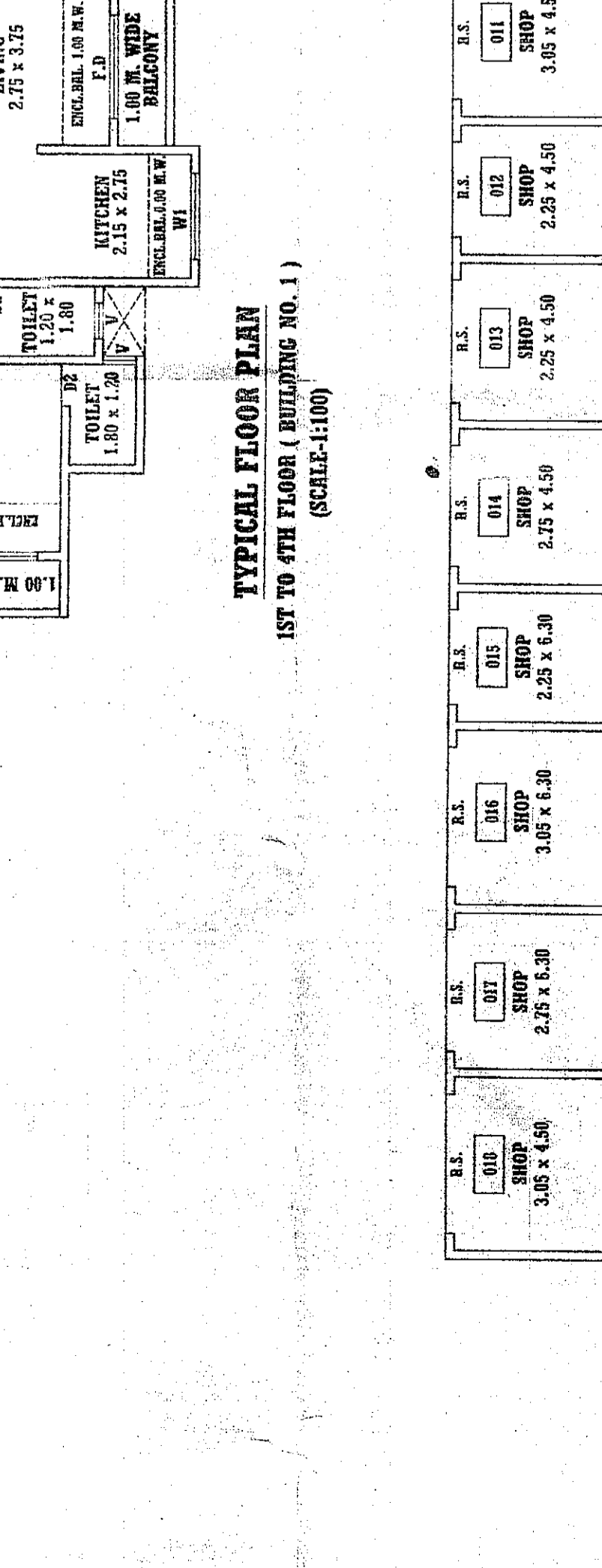
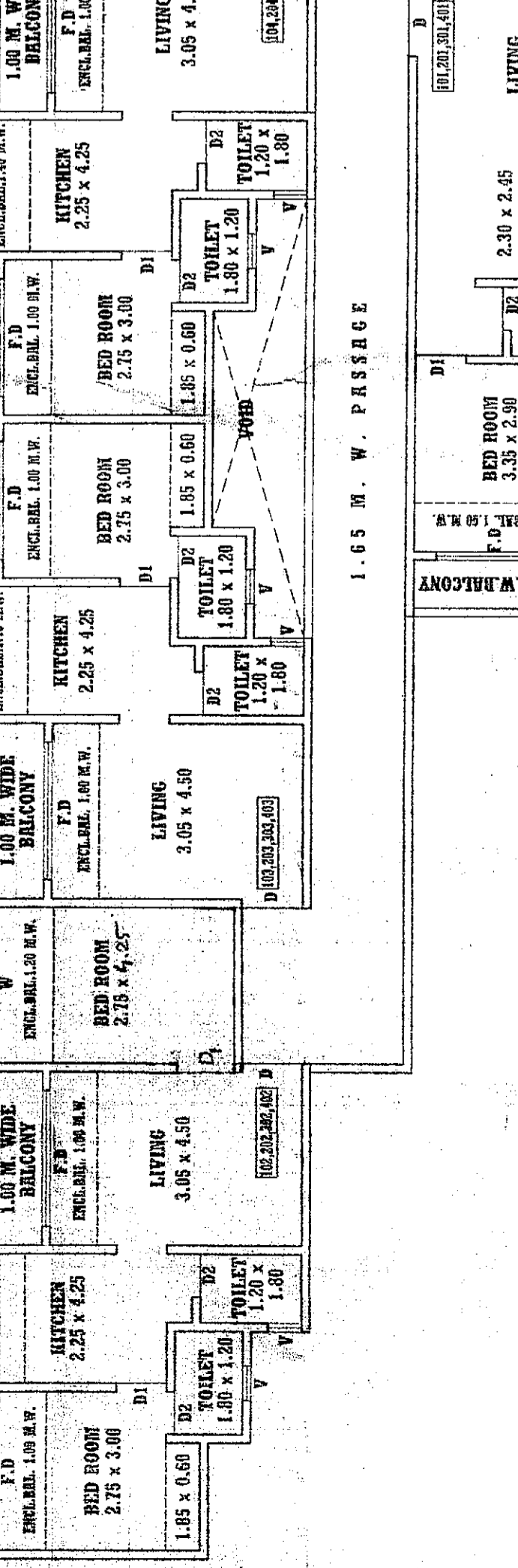
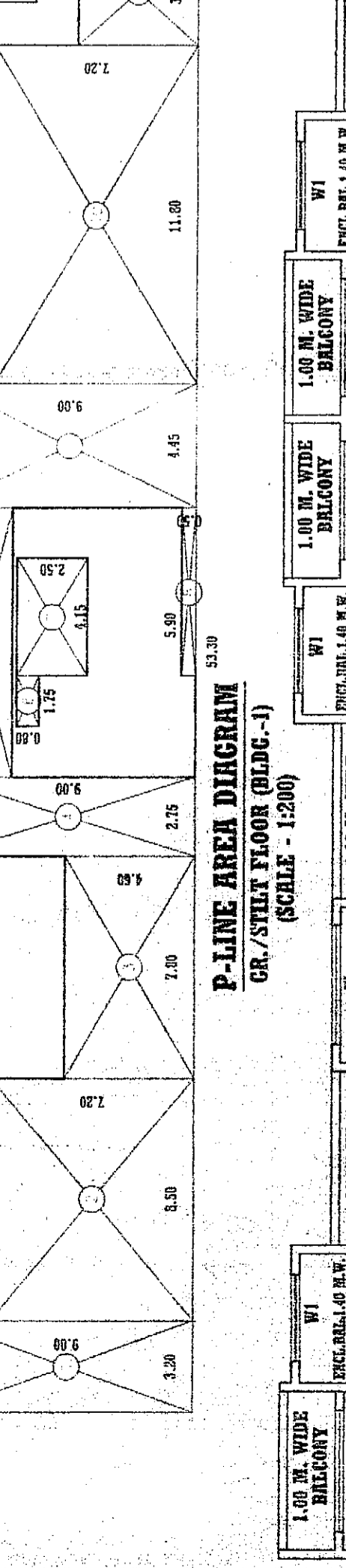
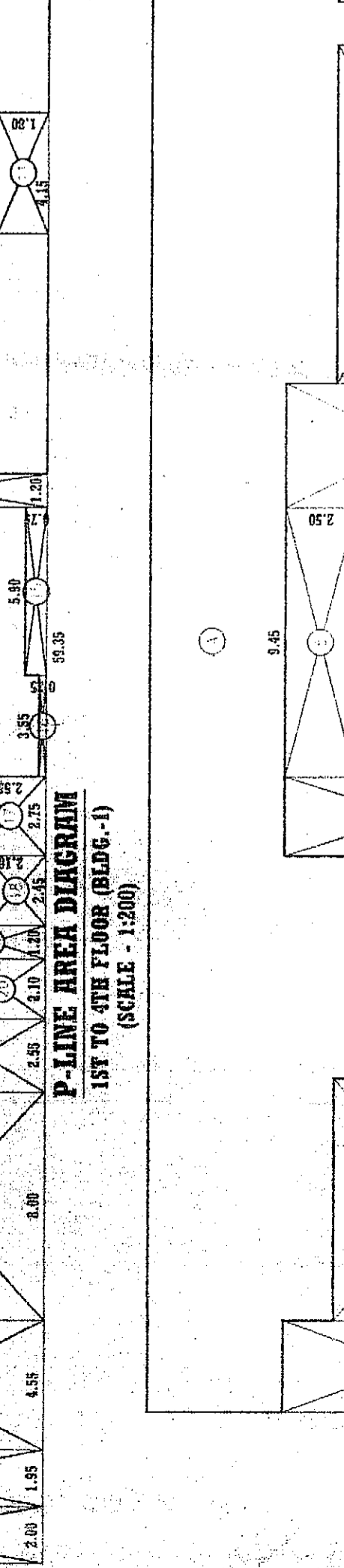
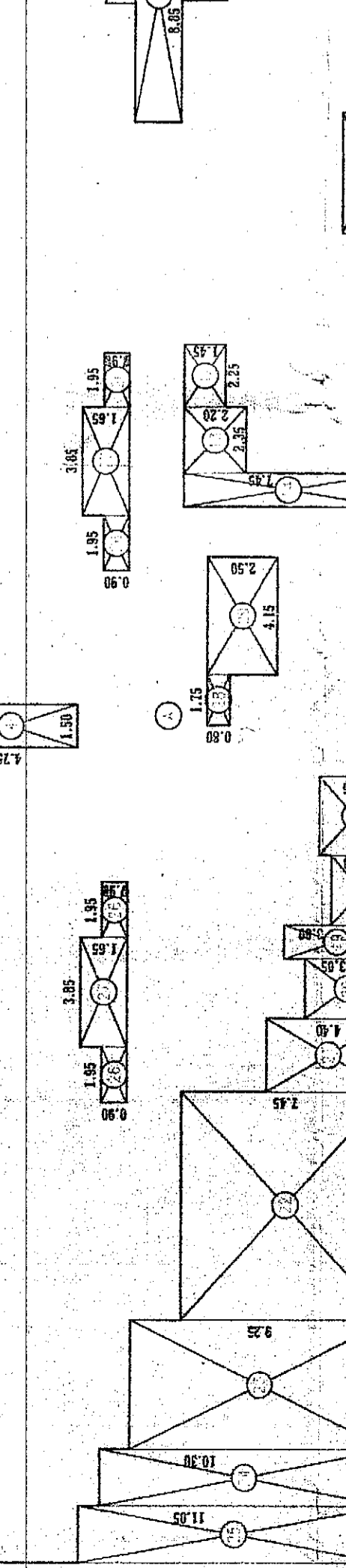

Table titled 'EXISTING STRUCTURE AREA' with columns for area (A-G) and details. It lists the area of existing structures on the plot.

Table titled 'D.P. ROAD AREA' with columns for area (A-G) and details. It lists the area of the drainage pipe road.

Table titled 'PLOT AREA STATEMENT' showing the total area of the plot and the area of various structures and roads.



APPENDIX - C
THE PLAN PREPARED BY ME ARE IN ACCORDANCE WITH THE NORMS AS SPECIFIED BY INDIAN STANDARD INSTITUTION. I WILL BE HELD RESPONSIBLE FOR ANY HARM CAUSED IN EARTHQUAKE DUE TO NEGLIGENCE OF THE STANDARDS.

CERTIFICATE OF AREA
I HAVE SURVEYED THE PLOT UNDER REFERENCE ON 2022 AND THAT THE DIMENSIONS OF THE PLOT STATED ON THE PLAN ARE AS MEASURED ON THE GROUND AND CORRECTED TO IN METRIC UNITS AND VALUES WITH THE AREA STATED IN THE DRAWINGS OF CONSTRUCTION PLANS BEING CORRECT.

OWNER'S DECLARATION -
I, THE UNDERSIGNED, HEREBY CONFIRM THAT THE ABOVE PLANS WERE APPROVED BY AUTHORITY AND EXECUTE THE WORK UNDER SUPERVISION OF PROPER TECHNICAL PERSONS TO ENSURE THE QUALITY AND SAFETY AT THE WORK SITE.

NAME & SIGNATURE OF OWNER
NAME & SIGNATURE OF ARCHITECT

PROPOSED BUILDING PERMISSION ON PLOT BEARING S.NO.12, H.NO. 11 AT VILLAGE - PISAVALI - TAL. KALYAN, DIST. THANE.

DESIGNER'S DECLARATION
I, THE UNDERSIGNED, HEREBY CONFIRM THAT THE ABOVE PLANS WERE APPROVED BY AUTHORITY AND EXECUTE THE WORK UNDER SUPERVISION OF PROPER TECHNICAL PERSONS TO ENSURE THE QUALITY AND SAFETY AT THE WORK SITE.

DESIGNER'S DECLARATION
I, THE UNDERSIGNED, HEREBY CONFIRM THAT THE ABOVE PLANS WERE APPROVED BY AUTHORITY AND EXECUTE THE WORK UNDER SUPERVISION OF PROPER TECHNICAL PERSONS TO ENSURE THE QUALITY AND SAFETY AT THE WORK SITE.

DESIGNER'S DECLARATION
I, THE UNDERSIGNED, HEREBY CONFIRM THAT THE ABOVE PLANS WERE APPROVED BY AUTHORITY AND EXECUTE THE WORK UNDER SUPERVISION OF PROPER TECHNICAL PERSONS TO ENSURE THE QUALITY AND SAFETY AT THE WORK SITE.

DESIGNER'S DECLARATION
I, THE UNDERSIGNED, HEREBY CONFIRM THAT THE ABOVE PLANS WERE APPROVED BY AUTHORITY AND EXECUTE THE WORK UNDER SUPERVISION OF PROPER TECHNICAL PERSONS TO ENSURE THE QUALITY AND SAFETY AT THE WORK SITE.

DESIGNER'S DECLARATION
I, THE UNDERSIGNED, HEREBY CONFIRM THAT THE ABOVE PLANS WERE APPROVED BY AUTHORITY AND EXECUTE THE WORK UNDER SUPERVISION OF PROPER TECHNICAL PERSONS TO ENSURE THE QUALITY AND SAFETY AT THE WORK SITE.

DESIGNER'S DECLARATION
I, THE UNDERSIGNED, HEREBY CONFIRM THAT THE ABOVE PLANS WERE APPROVED BY AUTHORITY AND EXECUTE THE WORK UNDER SUPERVISION OF PROPER TECHNICAL PERSONS TO ENSURE THE QUALITY AND SAFETY AT THE WORK SITE.

DESIGNER'S DECLARATION
I, THE UNDERSIGNED, HEREBY CONFIRM THAT THE ABOVE PLANS WERE APPROVED BY AUTHORITY AND EXECUTE THE WORK UNDER SUPERVISION OF PROPER TECHNICAL PERSONS TO ENSURE THE QUALITY AND SAFETY AT THE WORK SITE.

DESIGNER'S DECLARATION
I, THE UNDERSIGNED, HEREBY CONFIRM THAT THE ABOVE PLANS WERE APPROVED BY AUTHORITY AND EXECUTE THE WORK UNDER SUPERVISION OF PROPER TECHNICAL PERSONS TO ENSURE THE QUALITY AND SAFETY AT THE WORK SITE.

DESIGNER'S DECLARATION
I, THE UNDERSIGNED, HEREBY CONFIRM THAT THE ABOVE PLANS WERE APPROVED BY AUTHORITY AND EXECUTE THE WORK UNDER SUPERVISION OF PROPER TECHNICAL PERSONS TO ENSURE THE QUALITY AND SAFETY AT THE WORK SITE.

DESIGNER'S DECLARATION
I, THE UNDERSIGNED, HEREBY CONFIRM THAT THE ABOVE PLANS WERE APPROVED BY AUTHORITY AND EXECUTE THE WORK UNDER SUPERVISION OF PROPER TECHNICAL PERSONS TO ENSURE THE QUALITY AND SAFETY AT THE WORK SITE.

DESIGNER'S DECLARATION
I, THE UNDERSIGNED, HEREBY CONFIRM THAT THE ABOVE PLANS WERE APPROVED BY AUTHORITY AND EXECUTE THE WORK UNDER SUPERVISION OF PROPER TECHNICAL PERSONS TO ENSURE THE QUALITY AND SAFETY AT THE WORK SITE.

DESIGNER'S DECLARATION
I, THE UNDERSIGNED, HEREBY CONFIRM THAT THE ABOVE PLANS WERE APPROVED BY AUTHORITY AND EXECUTE THE WORK UNDER SUPERVISION OF PROPER TECHNICAL PERSONS TO ENSURE THE QUALITY AND SAFETY AT THE WORK SITE.

DESIGNER'S DECLARATION
I, THE UNDERSIGNED, HEREBY CONFIRM THAT THE ABOVE PLANS WERE APPROVED BY AUTHORITY AND EXECUTE THE WORK UNDER SUPERVISION OF PROPER TECHNICAL PERSONS TO ENSURE THE QUALITY AND SAFETY AT THE WORK SITE.

DESIGNER'S DECLARATION
I, THE UNDERSIGNED, HEREBY CONFIRM THAT THE ABOVE PLANS WERE APPROVED BY AUTHORITY AND EXECUTE THE WORK UNDER SUPERVISION OF PROPER TECHNICAL PERSONS TO ENSURE THE QUALITY AND SAFETY AT THE WORK SITE.

DESIGNER'S DECLARATION
I, THE UNDERSIGNED, HEREBY CONFIRM THAT THE ABOVE PLANS WERE APPROVED BY AUTHORITY AND EXECUTE THE WORK UNDER SUPERVISION OF PROPER TECHNICAL PERSONS TO ENSURE THE QUALITY AND SAFETY AT THE WORK SITE.

DESIGNER'S DECLARATION
I, THE UNDERSIGNED, HEREBY CONFIRM THAT THE ABOVE PLANS WERE APPROVED BY AUTHORITY AND EXECUTE THE WORK UNDER SUPERVISION OF PROPER TECHNICAL PERSONS TO ENSURE THE QUALITY AND SAFETY AT THE WORK SITE.