

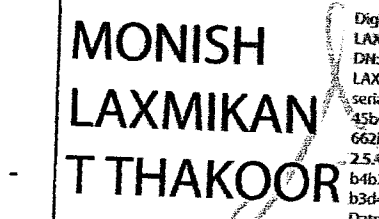

MCGM FILE NO. :- CHE/CTY/4561/G/N/337(NEW)				
PROFORMA 'B'				
DESCRIPTION OF PROPOSAL				
PROPOSED REDEVELOPMENT OF RESIDENTIAL BUILDING ON F.P. No. 634, T.P.S. IV, OF MAHIM DIV. GN - WARD, SITUATED AT DR. VASANT J. RATH MARG., SHIVAJI PARK, DADAR (W) MUMBAI- 400 028. AS PER D.C.R. 33/7 OF 1991.				
DIGITAL SIGNATURE FOR APPROVAL OF PLAN				
DNYANDIP BHAGWAN KASAVKAR	Vaibhav Bhargava Gandhi	Rajesh Santoshkumar Dholay		
SUB.-ENG (B.P.)CITY- III	ASST.-ENG (B.P.)CITY- VII	EX-ENG (B.P.)CITY- III		
NAME OF OWNER		SIGNATURE		
MONISH LAXMIKANT THAKOOR M/s. BUILDARCH LAND DEVELOPERS LTD. C.A. TO OWNER SULBHA JAGDISH DIGHE 1ST FLOOR, SANKALP P.S.H.PARALKAR, MARG. - SHIVAJI PARK DADAR (W) MUMBAI-400028		 <small>Digitally signed by MONISH LAXMIKANT THAKOOR DN: cn=MONISH LAXMIKANT THAKOOR, o=MONISH LAXMIKANT THAKOOR, ou=MONISH LAXMIKANT THAKOOR, email=monish.thakoor@buildarch.com, c=IN, date=2021.01.22 12:22:22 +05'30'</small>		
NAME & ADDRESS OF ARCHITECT		SIGNATURE		
 ANIL R. PATIL <small>ARCHITECTS, PLANNERS, INTERIOR DESIGNERS & B.M.C. CONSULTANTS OFFICE: 101, WARDHARA, 100, 102, 103, 104, 105, 106, 107, 108, 109, 110, 111, 112, 113, 114, 115, 116, 117, 118, 119, 120, 121, 122, 123, 124, 125, 126, 127, 128, 129, 130, 131, 132, 133, 134, 135, 136, 137, 138, 139, 140, 141, 142, 143, 144, 145, 146, 147, 148, 149, 150, 151, 152, 153, 154, 155, 156, 157, 158, 159, 160, 161, 162, 163, 164, 165, 166, 167, 168, 169, 170, 171, 172, 173, 174, 175, 176, 177, 178, 179, 180, 181, 182, 183, 184, 185, 186, 187, 188, 189, 190, 191, 192, 193, 194, 195, 196, 197, 198, 199, 200, 201, 202, 203, 204, 205, 206, 207, 208, 209, 210, 211, 212, 213, 214, 215, 216, 217, 218, 219, 220, 221, 222, 223, 224, 225, 226, 227, 228, 229, 230, 231, 232, 233, 234, 235, 236, 237, 238, 239, 240, 241, 242, 243, 244, 245, 246, 247, 248, 249, 250, 251, 252, 253, 254, 255, 256, 257, 258, 259, 260, 261, 262, 263, 264, 265, 266, 267, 268, 269, 270, 271, 272, 273, 274, 275, 276, 277, 278, 279, 280, 281, 282, 283, 284, 285, 286, 287, 288, 289, 290, 291, 292, 293, 294, 295, 296, 297, 298, 299, 300, 301, 302, 303, 304, 305, 306, 307, 308, 309, 310, 311, 312, 313, 314, 315, 316, 317, 318, 319, 320, 321, 322, 323, 324, 325, 326, 327, 328, 329, 330, 331, 332, 333, 334, 335, 336, 337, 338, 339, 340, 341, 342, 343, 344, 345, 346, 347, 348, 349, 350, 351, 352, 353, 354, 355, 356, 357, 358, 359, 360, 361, 362, 363, 364, 365, 366, 367, 368, 369, 370, 371, 372, 373, 374, 375, 376, 377, 378, 379, 380, 381, 382, 383, 384, 385, 386, 387, 388, 389, 390, 391, 392, 393, 394, 395, 396, 397, 398, 399, 400, 401, 402, 403, 404, 405, 406, 407, 408, 409, 410, 411, 412, 413, 414, 415, 416, 417, 418, 419, 420, 421, 422, 423, 424, 425, 426, 427, 428, 429, 430, 431, 432, 433, 434, 435, 436, 437, 438, 439, 440, 441, 442, 443, 444, 445, 446, 447, 448, 449, 450, 451, 452, 453, 454, 455, 456, 457, 458, 459, 460, 461, 462, 463, 464, 465, 466, 467, 468, 469, 470, 471, 472, 473, 474, 475, 476, 477, 478, 479, 480, 481, 482, 483, 484, 485, 486, 487, 488, 489, 490, 491, 492, 493, 494, 495, 496, 497, 498, 499, 500, 501, 502, 503, 504, 505, 506, 507, 508, 509, 510, 511, 512, 513, 514, 515, 516, 517, 518, 519, 520, 521, 522, 523, 524, 525, 526, 527, 528, 529, 530, 531, 532, 533, 534, 535, 536, 537, 538, 539, 540, 541, 542, 543, 544, 545, 546, 547, 548, 549, 550, 551, 552, 553, 554, 555, 556, 557, 558, 559, 560, 561, 562, 563, 564, 565, 566, 567, 568, 569, 570, 571, 572, 573, 574, 575, 576, 577, 578, 579, 580, 581, 582, 583, 584, 585, 586, 587, 588, 589, 590, 591, 592, 593, 594, 595, 596, 597, 598, 599, 600, 601, 602, 603, 604, 605, 606, 607, 608, 609, 610, 611, 612, 613, 614, 615, 616, 617, 618, 619, 620, 621, 622, 623, 624, 625, 626, 627, 628, 629, 630, 631, 632, 633, 634, 635, 636, 637, 638, 639, 640, 641, 642, 643, 644, 645, 646, 647, 648, 649, 650, 651, 652, 653, 654, 655, 656, 657, 658, 659, 660, 661, 662, 663, 664, 665, 666, 667, 668, 669, 670, 671, 672, 673, 674, 675, 676, 677, 678, 679, 680, 681, 682, 683, 684, 685, 686, 687, 688, 689, 690, 691, 692, 693, 694, 695, 696, 697, 698, 699, 700, 701, 702, 703, 704, 705, 706, 707, 708, 709, 710, 711, 712, 713, 714, 715, 716, 717, 718, 719, 720, 721, 722, 723, 724, 725, 726, 727, 728, 729, 730, 731, 732, 733, 734, 735, 736, 737, 738, 739, 740, 741, 742, 743, 744, 745, 746, 747, 748, 749, 750, 751, 752, 753, 754, 755, 756, 757, 758, 759, 760, 761, 762, 763, 764, 765, 766, 767, 768, 769, 770, 771, 772, 773, 774, 775, 776, 777, 778, 779, 780, 781, 782, 783, 784, 785, 786, 787, 788, 789, 790, 791, 792, 793, 794, 795, 796, 797, 798, 799, 800, 801, 802, 803, 804, 805, 806, 807, 808, 809, 810, 811, 812, 813, 814, 815, 816, 817, 818, 819, 820, 821, 822, 823, 824, 825, 826, 827, 828, 829, 830, 831, 832, 833, 834, 835, 836, 837, 838, 839, 840, 841, 842, 843, 844, 845, 846, 847, 848, 849, 850, 851, 852, 853, 854, 855, 856, 857, 858, 859, 860, 861, 862, 863, 864, 865, 866, 867, 868, 869, 870, 871, 872, 873, 874, 875, 876, 877, 878, 879, 880, 881, 882, 883, 884, 885, 886, 887, 888, 889, 890, 891, 892, 893, 894, 895, 896, 897, 898, 899, 900, 901, 902, 903, 904, 905, 906, 907, 908, 909, 910, 911, 912, 913, 914, 915, 916, 917, 918, 919, 920, 921, 922, 923, 924, 925, 926, 927, 928, 929, 930, 931, 932, 933, 934, 935, 936, 937, 938, 939, 940, 941, 942, 943, 944, 945, 946, 947, 948, 949, 950, 951, 952, 953, 954, 955, 956, 957, 958, 959, 960, 961, 962, 963, 964, 965, 966, 967, 968, 969, 970, 971, 972, 973, 974, 975, 976, 977, 978, 979, 980, 981, 982, 983, 984, 985, 986, 987, 988, 989, 990, 991, 992, 993, 994, 995, 996, 997, 998, 999, 1000</small>		 <small>Digitally signed by ANIL RAMAKANT PATIL DN: cn=ANIL RAMAKANT PATIL, o=ANIL RAMAKANT PATIL, ou=ANIL RAMAKANT PATIL, email=anil.patil@anilrpatil.com, c=IN, date=2021.01.22 12:22:22 +05'30'</small>		
DRG.NO.	DRAWN BY	CHECKED BY	DATE	SCALE
2	GANESH PALKAR	SAMEER NANDLASKAR	20/01/2021	1:100

COLUMN LESS CARPET AREA CALCULATION WITH LINE DIAGRAM

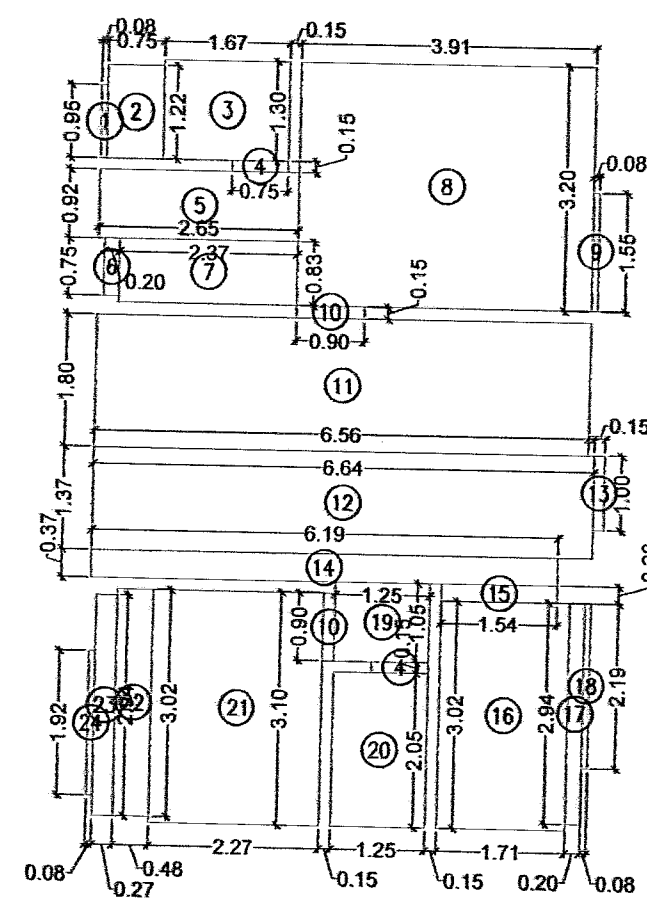

LINE DIAGRAM FOR CARPET AREA
TYP. FLR. 3RD, 4TH & 6TH TO 11TH, 13TH & 14TH
SCALE 1: 100

CARPET AREA CALCULATION

FLAT No.	4TH, 5TH, 7TH TO 12TH, 14TH & 15TH	(10)
1	0.08 X 0.95 X 1NO	= 0.08 SQ.MT.
2	0.75 X 1.22 X 1NO	= 0.92 SQ.MT.
3	1.67 X 1.30 X 1NO	= 2.17 SQ.MT.
4	0.75 X 0.15 X 2NOS	= 0.23 SQ.MT.
5	2.65 X 0.92 X 1NO	= 2.44 SQ.MT.
6	0.20 X 0.75 X 1NO	= 0.15 SQ.MT.
7	2.37 X 0.83 X 1NO	= 1.97 SQ.MT.
8	3.91 X 3.20 X 1NO	= 12.51 SQ.MT.
9	0.08 X 1.55 X 1NO	= 0.12 SQ.MT.
10	0.90 X 0.15 X 2NOS	= 0.27 SQ.MT.
11	6.56 X 1.80 X 1NO	= 11.81 SQ.MT.
12	6.64 X 1.37 X 1NO	= 9.10 SQ.MT.
13	0.15 X 1.00 X 1NO	= 0.15 SQ.MT.
14	6.19 X 0.37 X 1NO	= 2.29 SQ.MT.
15	1.54 X 0.23 X 1NO	= 0.35 SQ.MT.
16	1.71 X 3.02 X 1NO	= 5.16 SQ.MT.
17	0.20 X 2.94 X 1NO	= 0.59 SQ.MT.
18	0.08 X 2.19 X 1NO	= 0.18 SQ.MT.
19	1.25 X 1.05 X 1NO	= 1.31 SQ.MT.
20	1.25 X 2.05 X 1NO	= 2.56 SQ.MT.
21	2.27 X 3.10 X 1NO	= 7.04 SQ.MT.
22	0.48 X 3.02 X 1NO	= 1.45 SQ.MT.
23	0.27 X 2.94 X 1NO	= 0.79 SQ.MT.
24	0.08 X 1.92 X 1NO	= 0.15 SQ.MT.
TOTAL ADDITION		= 63.79 SQ.MT.

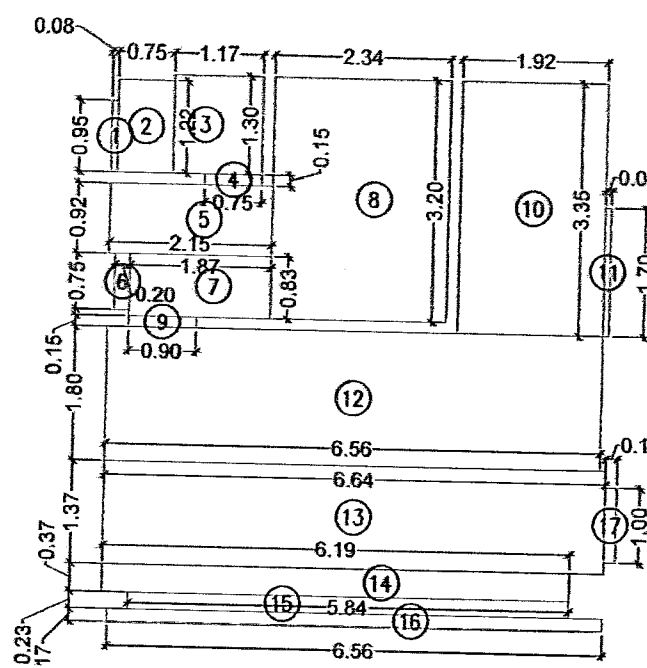

LINE DIAGRAM FOR CARPET AREA
FLOOR 6TH
SCALE 1: 100

CARPET AREA CALCULATION

FLAT No.	601	(01)
1	0.08 X 0.95 X 1NO	= 0.08 SQ.MT.
2	0.75 X 1.22 X 1NO	= 0.92 SQ.MT.
3	1.17 X 1.30 X 1NO	= 1.52 SQ.MT.
4	0.75 X 0.15 X 1NO	= 0.11 SQ.MT.
5	2.15 X 0.92 X 1NO	= 1.98 SQ.MT.
6	0.20 X 0.75 X 1NO	= 0.15 SQ.MT.
7	1.87 X 0.83 X 1NO	= 1.55 SQ.MT.
8	2.34 X 3.20 X 1NO	= 7.49 SQ.MT.
9	0.90 X 0.15 X 1NO	= 0.14 SQ.MT.
10	1.92 X 3.35 X 1NO	= 6.43 SQ.MT.
11	0.08 X 1.70 X 1NO	= 0.14 SQ.MT.
12	6.56 X 1.80 X 1NO	= 11.81 SQ.MT.
13	6.64 X 1.37 X 1NO	= 9.10 SQ.MT.
14	6.19 X 0.37 X 1NO	= 2.29 SQ.MT.
15	5.84 X 0.23 X 1NO	= 1.34 SQ.MT.
16	6.56 X 0.17 X 1NO	= 1.12 SQ.MT.
17	0.15 X 1.00 X 1NO	= 0.15 SQ.MT.
TOTAL ADDITION		= 46.32 SQ.MT.

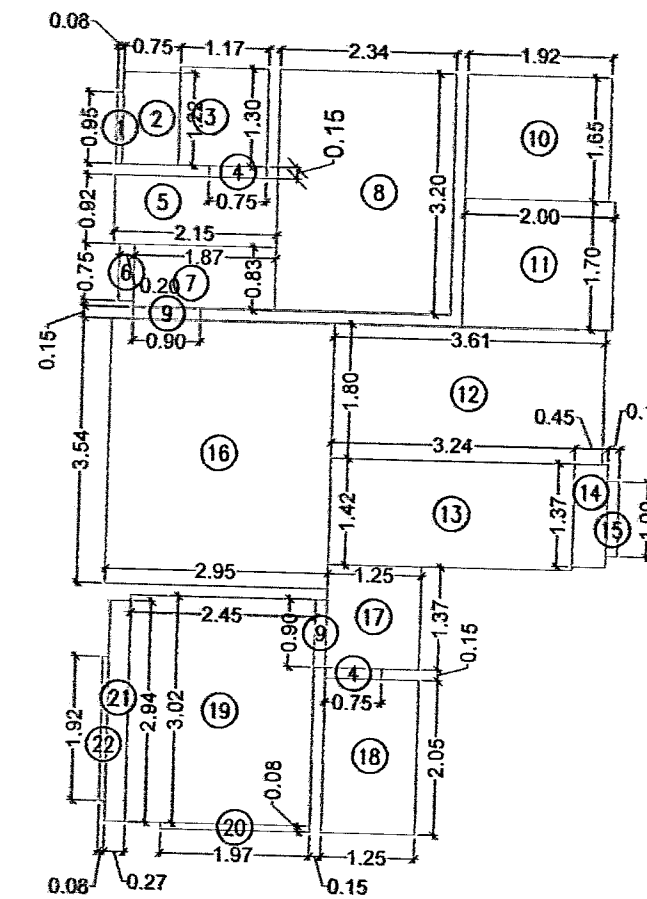

LINE DIAGRAM FOR CARPET AREA
FLOOR 13TH
SCALE 1: 100

CARPET AREA CALCULATION

FLAT No.	1301	(01)
1	0.08 X 0.95 X 1NO	= 0.08 SQ.MT.
2	0.75 X 1.22 X 1NO	= 0.92 SQ.MT.
3	1.17 X 1.30 X 1NO	= 1.52 SQ.MT.
4	0.75 X 0.15 X 2NOS	= 0.23 SQ.MT.
5	2.15 X 0.92 X 1NO	= 1.98 SQ.MT.
6	0.20 X 0.75 X 1NO	= 0.15 SQ.MT.
7	1.87 X 0.83 X 1NO	= 1.55 SQ.MT.
8	2.34 X 3.20 X 1NO	= 7.49 SQ.MT.
9	0.90 X 0.15 X 2NOS	= 0.27 SQ.MT.
10	1.92 X 1.65 X 1NO	= 3.17 SQ.MT.
11	2.00 X 1.70 X 1NO	= 3.40 SQ.MT.
12	3.61 X 1.80 X 1NO	= 6.50 SQ.MT.
13	3.24 X 1.42 X 1NO	= 4.60 SQ.MT.
14	0.45 X 1.37 X 1NO	= 0.62 SQ.MT.
15	0.15 X 1.00 X 1NO	= 0.15 SQ.MT.
16	2.95 X 3.54 X 1NO	= 10.44 SQ.MT.
17	1.25 X 1.37 X 1NO	= 1.71 SQ.MT.
18	1.25 X 2.05 X 1NO	= 2.56 SQ.MT.
19	2.45 X 3.02 X 1NO	= 7.40 SQ.MT.
20	1.97 X 0.08 X 1NO	= 0.16 SQ.MT.
21	0.27 X 2.94 X 1NO	= 0.79 SQ.MT.
22	0.08 X 1.92 X 1NO	= 0.15 SQ.MT.
TOTAL ADDITION		= 55.84 SQ.MT.

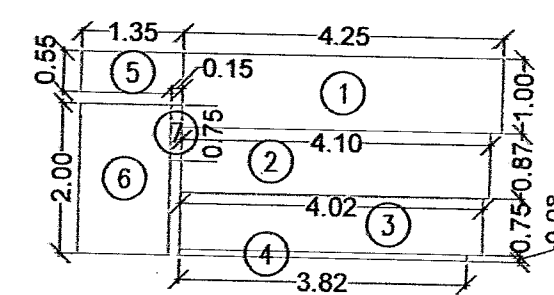

LINE DIAGRAM FOR CARPET AREA
FLOOR 3RD
SCALE 1: 100

CARPET AREA CALCULATION

FLAT No.	301	(01)
1	4.25 X 1.00 X 1NO	= 4.25 SQ.MT.
2	4.10 X 0.87 X 1NO	= 3.57 SQ.MT.
3	4.02 X 0.75 X 1NO	= 3.02 SQ.MT.
4	3.82 X 0.08 X 1NO	= 0.31 SQ.MT.
5	1.35 X 0.55 X 1NO	= 0.74 SQ.MT.
6	1.20 X 2.00 X 1NO	= 2.40 SQ.MT.
7	0.15 X 0.75 X 1NO	= 0.11 SQ.MT.
TOTAL ADDITION		= 14.40 SQ.MT.

Table 21 Details of Fungible FSI / Proposed for existing occupant / Tenants on plot bearing F P NO 634 TPS IV Mahim

Sr. No.	Name of Tenement/Occupant / Member of society	Name of Occupant	R/NR as per MHADA certified	Proposed flat (Tentative location)	Details of existing carpet area Certified by Mhada				5% Additional area proposed over and above area certified by Mhada	Details of proposed carpet area				carpet area considered for incentive purpose F.S.I.	Carpet area considered for fungible proposed F.S.I.	Permissible B.U.A.R.	Permissible Fungible B.U.A.In Sq. Mts.	Fungible B.U.A. for Common Amenities	Net Permissible Fungible B.U.A.	Total Permissible B.U.A. including fungible B.U.A.	Total Proposed B.U.A.	Fungible B.U.A.	
					Flat No.	Floor	Existing carpet area	Common Carpet Area SQ.MT.		Balcony Carpet Area	Total Carpet Area (6+7)	Carpet Area Sq. mt. (9+10)	Total Proposed carpet area as per Plan									Fungible Area features like balcony flower bed, terrace Sq. mt.	Min of 9 & 10 Max X 70
1	Mr. Subhash Shankar Tamhane	Mr. Subhash Shankar Tamhane	Resident	401 & 501	4TH & 5th	87.61	5.76	0	93.37	4.67	98.04	129.44	Not Applicable	120.00	98.04	117.65	41.18	Not Considerd	41.18	158.82	144.90	0	13.92
2	Smt. Subhash Jagdish Dighe	Smt. Subhash Jagdish Dighe	Resident	601, 901 & 1002	6TH, 9TH & 10TH	95.27	4.44	0	99.71	4.99	104.70	176.42	Not Applicable	120.00	104.70	125.63	43.97	Not Considerd	43.97	169.61	197.57	27.96	0
3	Mr. Dwarikadas Dhanji Bhai Mehta	Mr. Dwarikadas Dhanji Bhai Mehta	Resident	701&801	7TH & 8TH	91.42	10.00	0	101.42	5.07	106.49	129.44	Not Applicable	120.00	106.49	127.79	44.73	Not Considerd	44.73	172.52	144.90	0	27.62
Total						274.30	20.20	0	294.50	14.73	309.23	435.30		360.00	309.23	371.07	129.87		129.87	500.94	487.37	27.96	41.54

1) NOTES :-
COLUMN NUMBER 1 TO 15 ARE GIVEN BY MHADA.

MCGM FILE NO. :- CHE/CTY/4561/G/N/337(NEW)
DESCRIPTION OF PROPOSAL
PROPOSED REDEVELOPMENT OF RESIDENTIAL BUILDING ON F.P. No. 634, T.P.S. IV, OF MAHIM DIV., G/N - WARD, SITUATED AT DR. VASANT J. RATH MARG., SHIVAJI PARK, DADAR (W) MUMBAI- 400 028. AS PER D.C.R. 33/7 OF 1991.

NAME OF OWNER	SIGNATURE			
MONISH LAXMIKANT THAKOOR M/s. BUILDHAR LAND DEVELOPERS .LTD. C.A. TO OWNER SULBHA JAGDISH DIGHE 1ST FLOOR, SANKALP P.S.H.PARALKAR, MARG. - SHIVAJI PARK DADAR (W) MUMBAI-400028	MONISH LAXMIKANT THAKOOR Digitally signed by MONISH LAXMIKANT THAKOOR DN: cn=MONISH LAXMIKANT THAKOOR, serialNumber=76c1214e39adax279c45bc19421ae7259afac5c8b4efc962b38367, postalCode=400016, 2.5.4.20=3e161d43d365d240b99ec20594b286e279943c52389aec57f3d705284464ec, st=Maharashtra Date: 2021.01.22 12:32:47 +05'30'			
NAME, ADDRESS & SIGNATURE OF ARCHITECT	SIGNATURE			
ANIL R. PATIL ARCHITECTS, PLANNERS, INTERIOR DESIGNERS & B.M.C. CONSULTANTS CORP. PORTUGUESE CHURCH, DADAR DADAR (WEST), MUMBAI- 400 028 TELEFAX: 2532111, MOB: 932276493 E-MAIL: anilrpatil@gmail.com	ANIL RAMAKANT PATIL Digitally signed by ANIL RAMAKANT PATIL DN: cn=ANIL RAMAKANT PATIL, serialNumber=22f023a, postalCode=400016, 2.5.4.20=3e161d43d365d240b99ec20594b286e279943c52389aec57f3d705284464ec, st=Maharashtra Date: 2021.01.22 12:34:02 +05'30'			
DRG.NO.	DRAWN BY	CHECKED BY	DATE	SCALE
3	GANESH PALKAR	SAMEER NANDLASKAR	20/01/2021	1:100