

Valuation Report of the Immovable Property

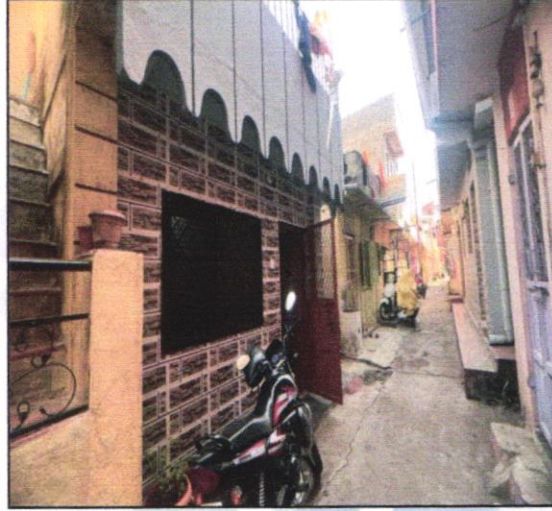

Details of the property under consideration:

Name of Owner: **Shri.Suresh Jagannath Vispute & Sau.Shilpa Suresh Vispute**

Residential Land and House on **Tenement No. N9/FE/06/04**, Ground + First Floor, Second Scheme, Neighborhood Falgun Sector, Behind Mahesh Medical, Prabhat Colony, Maharana Pratap Chowk, Village – CIDCO, Taluka – Nashik, District – Nashik, Pin Code – 422 009, State - Maharashtra, Country – India.

Longitude Latitude: 19°58'28.1"N 73°45'58.8"E

Intended User: **Bank of Baroda** **Regional Office**

BSNL Building, Datta Mandir Road, Nashik Road,
Nashik, PIN – 422 101, State - Maharashtra, Country - India.

Nashik: 4, 1st Floor, Madhusha Elite, Vrundavan Nagar, Jatra Nandu Naka Link Road, Adgaon, Nashik-422003 (M.S.), INDIA
Email: nashik@vastukala.co.in | Tel : +91 253 4068262/98903 80564

Our Pan India Presence at :

📍 Nanded 📍 Thane 📍 Ahmedabad 📍 Delhi NCR
📍 Mumbai 📍 Nashik 📍 Rajkot 📍 Raipur
📍 Aurangabad 📍 Pune 📍 Indore 📍 Jaipur

Regd. Office

B1-001, U/B Floor, BOOMERANG, Chandivali Farm Road, Powai, Andheri East, **Mumbai** :400072, (M.S), India

☎ +91 22 47495919

✉ mumbai@vastukala.co.in

🌐 www.vastukala.co.in



Vastukala Consultants (I) Pvt. Ltd.

Valuation Report : BOB/ Regional Office / Shri.Suresh Jagannath Vispute (009340/2306817) Page 2 of 26

www.vastukala.co.in

Vastu/Nashik/06/2024/009340/2306817
19/11-261-CHBS
Date: 19.06.2024

1. VALUATION OPINION REPORT

This is to certify that the property bearing Residential Land and House on **Tenement No. N9/FE/06/04**, Ground + First Floor, Second Scheme, Neighborhood Falgun Sector, Behind Mahesh Medical, Prabhat Colony, Maharana Pratap Chowk, Village – CIDCO, Taluka – Nashik, District – Nashik, Pin Code – 422 009, State - Maharashtra, Country – India belongs **Shri.Suresh Jagannath Vispute & Sau.Shilpa Suresh Vispute**

Boundaries of the property.

North : Tenement No. N9/FE/06/03
South : Marginal Space (Bol)
East : Marginal Space .
West : Colony Road

Considering various parameters recorded, existing economic scenario, and the information that is available with reference to the development of neighborhood and method selected for valuation, we are of the opinion that, the property premises can be assessed and Fair Market Value for this particular purpose at is ₹ **20,23,275.00** (Rupees Twenty Lakh Twenty-Three Thousand Two Hundred Seventy-Five Only).

The valuation of the property is based on the documents produced by the concern. Legal aspects have not been taken into considerations while preparing this valuation report.

Hence certified

For **VASTUKALA CONSULTANTS (I) PVT. LTD.**

**Manoj
Chalikwar**

Director

Manoj B. Chalikwar

Registered Valuer

Chartered Engineer (India)

Reg. No. CAT-I-F-1763

Reg. No. IBBI/RV/07/2018/10366

BOB Empanelment No.: ZO:MZ:ADV:46:941

Digitally signed by Manoj Chalikwar
DN: cn=Manoj Chalikwar, o=Vastukala
Consultants (I) Pvt. Ltd., ou=Mumbai,
email=manoj@vastukala.org, c=IN
Date: 2024.06.19 17:49:00 +05'30'

Auth. Sign.

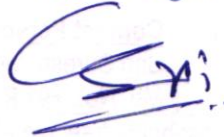

Nashik: 4, 1st Floor, Madhusha Elite, Vrundavan Nagar, Jatra Nandu Naka Link Road, Adgaon, Nashik-422003 (M.S.), INDIA
Email: nashik@vastukala.co.in | Tel : +91 253 4068262/98903 80564

Our Pan India Presence at :

📍 Nanded 📍 Thane 📍 Ahmedabad 📍 Delhi NCR
📍 Mumbai 📍 Nashik 📍 Rajkot 📍 Raipur
📍 Aurangabad 📍 Pune 📍 Indore 📍 Jaipur

Regd. Office

B1-001, U/B Floor, BOOMERANG, Chandivali Farm Road, Powai, Andheri East, **Mumbai** :400072, (M.S), India

📞 +91 22 47495919

✉️ mumbai@vastukala.co.in

🌐 www.vastukala.co.in



Vastukala Consultants (I) Pvt. Ltd.B1-001, U/B Floor, **Boomerang**, Chandivali Farm Road, Powai, Andheri (East), Mumbai – 400 072

To,

The Branch Manager,**Bank of Baroda****Regional Office**

3SNL Building, Datta Mandir Road, Nashik Road,

Vashik, PIN – 422 101, State - Maharashtra, Country - India.

2. VALUATION REPORT (IN RESPECT OF LAND AND BUILDING)

I	General	
1.	Purpose for which the valuation is made	: As per the request from Bank of Baroda, Mumbai Naka Regional Office Branch to assess Fair market value of the property for banking purpose
2.	a) Date of inspection	: 18.06.2024
	b) Date on which the valuation is made	: 19.06.2024
3.	List of documents produced for perusal	
	1. Copy Agreement of Assignment Vide No. 4044/2023 Dated.06.04.2023	
	2. Copy Tenement Transfer Order Letter No. CIDCO/ADMN/NSK/8952 dated 24.09.2018 issued by City Industrial Development Corporation of Maharashtra Limited	
	3. Copy of Possession Receipts Dated.31.05.1982 issued by City Industrial Development Corporation of Maharashtra Limited.	
	4. Copy of Approved Building Plan dated.01.06.2004 issued by Administrator issued by City Industrial Development Corporation of Maharashtra Limited, New Nashik.	
	5. Copy of Electricity Bill vide Consumer No.049014107206 dated 07.06.2024 in the name of Shri.Suresh Jagannath Vispute issued by M.S.E.D.C.L	
4.	Name of the owner(s) and his / their address (es) with Phone no. (details of share of each owner in case of joint ownership)	: Shri.Suresh Jagannath Vispute & Sau.Shilpa Suresh Vispute Address: Residential Land and House on Tenement No. N9/FE/06/04 , Ground + First Floor, Second Scheme, Neighborhood Falgun Sector, Behind Mahesh Medical, Prabhat Colony, Maharana Pratap Chowk, Village – CIDCO, Taluka – Nashik, District – Nashik, Pin Code – 422 009, State - Maharashtra, Country – India. Contact Person: Shri.Suresh Jagannath Vispute (Owner) Mb. No.: +91 9881383116.
5.	Brief description of the property (Including Leasehold / freehold etc.):	

The property is located in a developing Residential area having good infrastructure, well connected by road and train. The immovable property comprises of Leasehold Residential land and structures thereof. It is located at about 10.3 km. travelling distance from Nashik Road Railway Station.

Plot:

The plot under valuation is Leasehold residential plot. **As per Approved Plan Plot area is 39.60 Sq. M., which is considered for valuation.**

Structure:

As per site inspection structure are as under:

Description	As per site measurement Carpet Area in Sq. M.
RCC Framed Structure	
Ground Floor – Hall, Kitchen, Toilet, Staircase, Passage, Balcony.	36.84
First Floor – Bedroom, Staircase, Passage.	

As per Approved Plan Built Up area is 40.286 Sq. M., which is considered for valuation.

Floors	Area (Sq. M.)
Scheme Built Up	18.06
Ground Floor	10.07
First Floor	7.776
Staircase Area	4.38
Total Built up area	40.286

5a	Total Lease Period & remaining period (if leasehold)	:	N.A., the land is Leasehold
6.	Location of property	:	
a)	Plot No. / Survey No.	:	Second Scheme, Neighborhood Falgun Sector
b)	Door No.	:	Residential Land and House on Tenement No. N9/FE/06/04
c)	C.T.S. No. / Village	:	Village –CIDCO
d)	Ward / Taluka	:	Taluka – Nashik
e)	Mandal / District	:	District – Nashik
7.	Postal address of the property	:	Residential Land and House on Tenement No. N9/FE/06/04 , Ground + First Floor, Second Scheme, Neighborhood Falgun Sector, Behind Mahesh Medical, Prabhat Colony , Maharana Pratap Chowk, Village – CIDCO, Taluka – Nashik, District – Nashik, Pin Code – 422 009, State - Maharashtra, Country – India
8.	City / Town	:	Village – Cidco
	Residential area	:	Yes
	Commercial area	:	No
	Industrial area	:	No
9.	Classification of the area	:	
i)	High / Middle / Poor	:	Middle Class
ii)	Urban / Semi Urban / Rural	:	Urban

10.	Coming under Corporation limit / Village Panchayat / Municipality	:	Village – CIDCO City Industrial Development Corporation of Maharashtra Limited.
11.	Whether covered under any State / Central Govt. enactments (e.g., Urban Land Ceiling Act) or notified under agency area/ scheduled area / cantonment area	:	No
12.	In Case it is Agricultural land, any conversion to house site plots is contemplated	:	N.A.
13.	Dimensions / Boundaries of the property		A
			As per the Plan
			B
			Actual
	North		Tenement No. N9/FE/06/03
	South		Tenement No. N9/FE/06/03
	East		Marginal Space (Bol)
	West		Marginal Space (Bol)
			Marginal Space
			Colony Road
13.2	Latitude, Longitude & Co-ordinates of the site	:	19°58'28.1"N 73°45'58.8"E
14.	Extent of the site	:	Plot Area = 39.60 Sq. M.
15.	Extent of the site considered for Valuation (least of 13A& 13B)	:	(As per Approved Plan) Structure Area = As per table Attached
16	Whether occupied by the owner / tenant? If occupied by tenant since how long? Rent received per month.	:	Owner Occupied
II CHARACTERISTICS OF THE SITE			
1.	Classification of locality	:	Good
2.	Development of surrounding areas	:	Developing
3.	Possibility of frequent flooding/ submerging	:	No
4.	Feasibility to the Civic amenities like School, Hospital, Bus Stop, Market etc.	:	All available near by
5.	Level of land with topographical conditions	:	Plain
6.	Shape of land	:	Rectangular
7.	Type of use to which it can be put	:	For Residential purpose
8.	Any usage restriction	:	Residential
9.	Is plot in town planning approved layout?	:	N.A.
10.	Corner plot or intermittent plot?	:	Intermittent
11.	Road facilities	:	Yes
12.	Type of road available at present	:	B.T. Road
13.	Width of road – is it below 20 ft. or more than 20 ft.	:	Below 15 Ft
14.	Is it a Land – Locked land?	:	No
15.	Water potentiality	:	Connected to Municipal Supply Line
16.	Underground sewerage system	:	Connected to Septic Tank
17.	Is Power supply is available in the site	:	Yes
18.	Advantages of the site	:	Located in developing area
19.	Special remarks, if any like threat of acquisition of land for publics service	:	No

	purposes, road widening or applicability of CRZ provisions etc. (Distance from sea-cost / tidal level must be incorporated)	
Part – A (Valuation of land)		
1	Size of plot	: Plot Area = 39.60 Sq. M. (As per Approved Plan)
	North & South	: --
	East & West	: --
2	Total extent of the plot	: As per valuation table
3	Prevailing market rate (Along With details / reference of at least two latest deals / transactions with respect to adjacent properties in the areas)	: ₹ 40,000.00 to ₹ 50,000.00 per Sq. M.
4	Guideline rate obtained from the Registrar's Office	: ₹ 6,400.00 per Sq. M
	In case of variation of 20% or more in the valuation proposed by the valuer and the Guideline value provided in the State Govt. notification or Income Tax Gazette justification on variation has to be given.	: It is a foregone conclusion that market value is always more than RR prices. As the RR rates are fixed by respective state governments for computing stamp duty / regn. Fees. Thus, the rates differ from place to place and location. Amenities per se as evident from the fact that even RR rates decided by Govt. differ.
5	Assessed / adopted rate of valuation	: ₹ 43,000.00 per Sq. M.
6	Estimated value of land	: ₹ 17,02,800.00
Part – B (Valuation of Building)		
1	Technical details of the building	:
	a) Type of Building (Residential / Commercial / Residential)	: Residential
	b) Type of construction (Load bearing / RCC / Steel Framed)	: As per Brief Description
	c) Year of construction	: 1982 (As per Possession Receipt)
	d) Age of the building	: 42 Years
	e) Life of the building estimated	: 18 Years (Subject to proper, preventive periodic maintenance & structural repairs.)
	f) Number of floors and height of each floor including basement, if any	: As per Brief Description
	g) Plinth area floor-wise	: As per valuation table
	h) Condition of the building	:
	i) Exterior – Excellent, Good, Normal, Poor	: Good
	ii) Interior – Excellent, Good, Normal, Poor	: Good
	i) Date of issue and validity of layout of approved map	: Copy of Approved Building Plan dated.01.06.2004 issued by Administrator issued by City Industrial Development Corporation of Maharashtra Limited, New Nashik.
	j) Approved map / plan issuing authority	: Corporation of Maharashtra Limited, New Nashik.
	k) Whether genuineness or authenticity of approved map / plan is verified	: Industrial Development Corporation of Maharashtra Limited, New Nashik Yes
	l) Any other comments by our empanelled valuers on authentic of	: No

Sr. No.	Description	
approved plan		
Specifications of construction (floor-wise) in respect of		
1.	Foundation	: As per Brief Description
2.	Basement	: No
3.	Superstructure	:
4.	Joinery / Doors & Windows (Please furnish details about size of frames, shutters, glazing, fitting etc. and specify the species of timber	: Teak wood door frame with flush doors, MS Grill windows, Concealed plumbing & Concealed Electrical wiring.
5.		
6.		
7.		
8.	RCC Works	: RCC Framed Structure
9.	Plastering	: Cement Plastering
10.	Flooring, Skirting, dado	: Vitrified Tiles Flooring
11.	Special finish as marble, granite, wooden paneling, grills etc.	: Marble
12.		
13.	Roofing including weatherproof course	: As per Brief Description
14.	Drainage	: Connected to Municipal Sewerage System
15.	Compound Wall	:
	Height	: Not Applicable
	Length	:
	Type of construction	:
16.	Electrical installation	:
	Type of wiring	: Concealed
	Class of fittings (superior / ordinary / poor)	: Ordinary
	Number of light points	: Provided as per requirement
	Fan points	: Provided as per requirement
	Spare plug points	: Provided as per requirement
	Any other item	: Provided as per requirement
17.	Plumbing installation	:
	a) No. of water closets and their type	: Provided as per requirement
	b) No. of wash basins	: Provided as per requirement
	c) No. of urinals	: Provided as per requirement
	d) No. of bath tubs	: Provided as per requirement
	e) Water meters, taps etc.	: Provided as per requirement
	f) Any other fixtures	: Provided as per requirement

Details of Valuation: -

Items	Area In Sq. M.	Year Of Const.	Total Life of Structure	Full Rate	Age Of Build.	Depreciated Rate to be considered	Depreciated Value to be considered	Value / Full Value
Ground + First Floor	40.286	1982	60	21,500.00	42	7,955.00	3,20,475.00	8,66,149.00
						TOTAL	3,20,475.00	8,66,149.00

Part – C (Extra Items)		:	Amount in ₹
1.	Portico	:	Included in the Cost of Construction
2.	Ornamental front door	:	
3.	Sit out / Verandah with steel grills	:	
4.	Overhead water tank	:	
5.	Extra steel / collapsible gates	:	
Total			
Part – D (Amenities)		:	Amount in ₹
1.	Wardrobes	:	Included in the Cost of Construction
2.	Glazed tiles	:	
3.	Extra sinks and bathtub	:	
4.	Marble / ceramic tiles flooring	:	
5.	Interior decorations	:	
6.	Architectural elevation works	:	
7.	Paneling works	:	
8.	Aluminum works	:	
9.	Aluminum handrails	:	
10.	False ceiling	:	
Total			
Part – E (Miscellaneous)		:	Amount in ₹
1.	Separate toilet room	:	Included in the Cost of Construction
2.	Separate lumber room	:	
3.	Separate water tank / sump	:	
4.	Trees, gardening	:	
Total			
Part – F (Services)		:	Amount in ₹
1.	Water supply arrangements	:	Included in the Cost of Construction
2.	Drainage arrangements	:	
3.	Compound wall	:	
4.	C.B. deposits, fittings etc.	:	
5.	Pavement	:	
Total			

Government Value

Particulars	Area in Sq. M.	Rate in ₹	Value in ₹
Land	39.60	6,400.00	2,53,440.00
Structure	As per valuation table		3,20,475.00
Total			5,73,915.00

3. TOTAL ABSTRACT OF THE ENTIRE PROPERTY

Part – A	Land	:	₹ 17,02,800.00
Part – B	Building	:	₹ 3,20,475.00
Part – C	Extra Items	:	
Part – D	Amenities	:	
Part – E	Miscellaneous	:	
Part – F	Services	:	
	Total	:	₹ 20,23,275.00

Fair Market Value	:	₹ 20,23,275.00
Realizable Value	:	₹ 19,22,111.00
Distress Value	:	₹ 16,18,620.00
Value as per Circle Rate	:	₹ 5,73,915.00
Insurable value (Full Replacement Cost – Subsoil Structure cost (15%))	:	₹ 2,72,404.00

Remark:

1) *For the purpose of valuation, we have considered the Land and structure area as per Approved Plan.*

Justification for price / rate

The Market Value of the property is based on facts of markets discovered by us during our enquiries, however the government rate value in this case is less than the market value arrived by us. We are of the opinion that the value arrive by us will prove to be correct if an Auction of the subject property is carried out. As far as Market Value in Index II is concerned, it is not possible to comment on same, may be government rates are fixed by sampling during same point of time in part and whereas, Market values change every month.

In most of the cases the actual deal amount or Transaction value is not reflected in Index II because of various Market practices. As Valuer, we always try to give a value which is correct reflection of actual transaction value irrespective of any factors in market.

Method of Valuation / Approach

The cost approach is a Real Property Valuation method which considers the value of a property as the cost of the land plus the replacement cost of the building (construction costs) minus the physical and functional depreciation. This approach is most commonly used for real estate properties that are not easily sold like schools, hospitals, government buildings and above type of property.

Land cost can be estimated using the Sales Comparison Approach by studying recent sales of land close to the subject property, and these sales should be comparable in size and location with subject property.

There are different ways to estimate replacement costs, the most common being finding out the cost to build a square foot of comparable properties multiplied by the total square footage of the building. The cost approach is commonly used for Residential Bungalow, Residential Building and properties mentioned above.

As the property is an Residential land and building thereof, we have adopted Cost approach / Land and Building Method for the purpose of valuation. The Price for similar type of property in the nearby vicinity is in the range of ₹ 40,000.00 to ₹ 50,000.00 per Sq. M. for land and Structure thereof Considering the rate with attached report, current market conditions, demand and supply position, Land size, location, sustained demand for Residential building / Plot, all round development of commercial and Residential application in the locality etc.

We estimate ₹ 43,000.00 per Sq. M. for Land with appropriate cost of construction for valuation.

i) Saleability	Good
ii) Likely rental values in future in and	-
iii) Any likely income it may generate	-

4. ACTUAL SITE PHOTOGRAPHS



ROUTE MAP OF THE PROPERTY

Site w/r

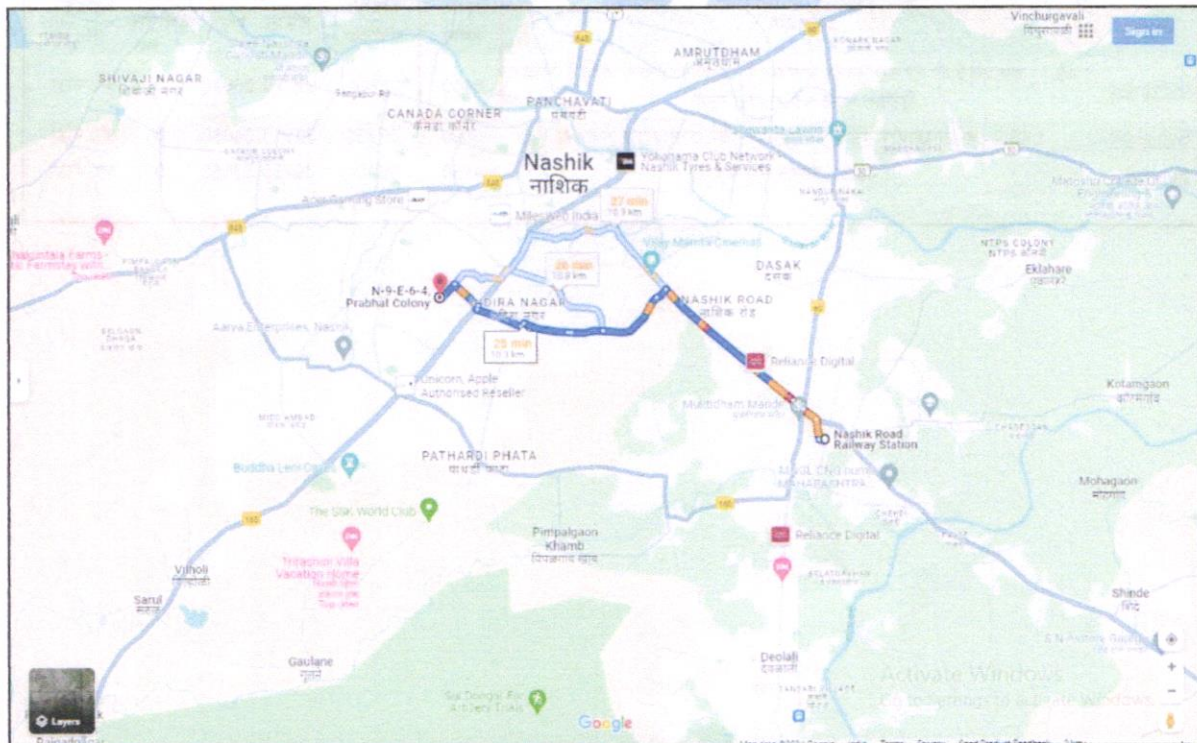
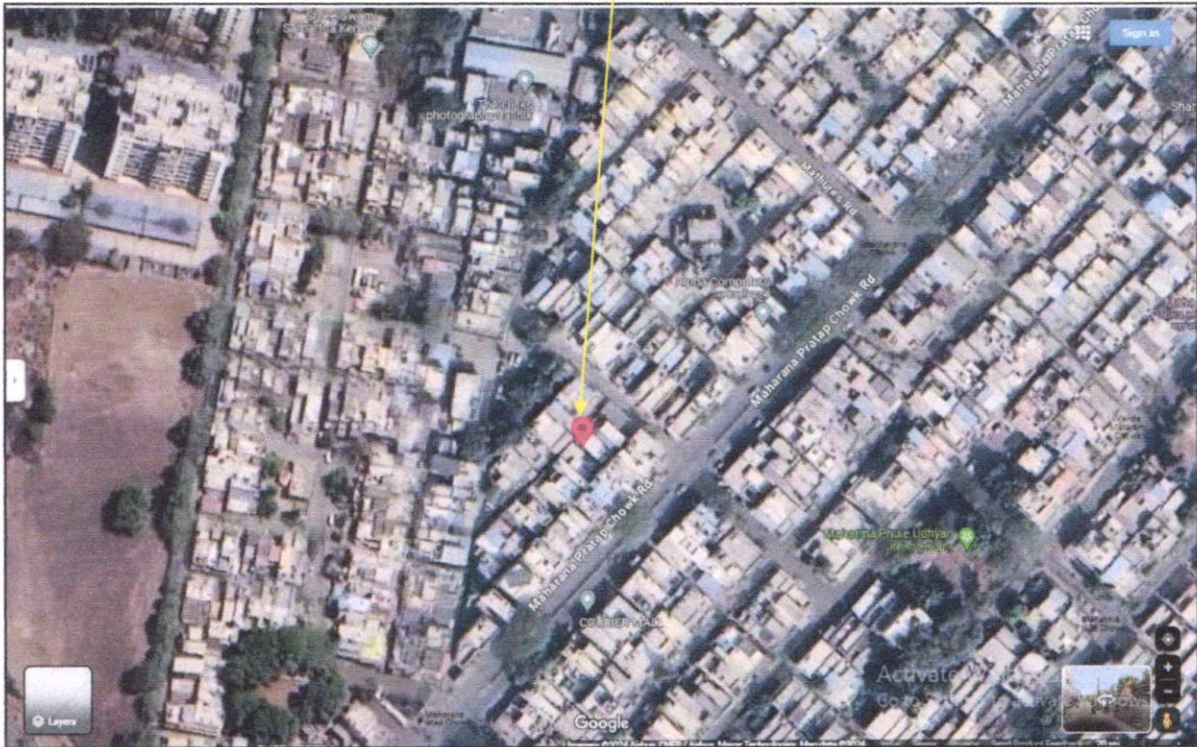

Longitude Latitude: 19°58'28.1"N 73°45'58.8"E

Note: The Blue line shows the route to site from nearest Railway Station (Nashik – 10.3 Km)



Since 1989

Vastukala Consultants (I) Pvt. Ltd.

An ISO 9001 : 2015 Certified Company



5. READY RECKONER RATE



Department of Registration and Stamp
Government of Maharashtra

नोंदणी व मुद्रांक विभाग
महाराष्ट्र शासन



Annual Statement of Rates Ver. 2.0 (बाजारमूल्य दर पत्रक आवृत्ती 2.0)

[Home](#)
[Valuation Guidelines](#) | [User Manual](#)

Year Language

Selected District

Select Taluka

Select Village

Search By Survey No. SubZones

Select	उपविभाग	खुली जमीन	निवासी सदनिका	ऑफिस	दुकाने	औद्योगिक	एकक (Rs./)
Survey/No	1.48.1 - एम.एस.ई.डी.सब स्टेशनवरून जाणारा मोरवाडी ते शिवाजी चौक ते सिव्हेन ट्रिडमेंट पर्यंत कडे जाणारा रस्ता.	6400	28500	32770	35620	0	चौ. मीटर
Survey/No	1.48.2 - करील रस्त्यापासून आत जाणा.या मुख्य रस्त्यावरील मिळकती	5800	27750	31910	34680	0	चौ. मीटर
Survey/No	1.48.3 - अंतर्गत मिळकती	4850	26120	29750	32650	0	चौ. मीटर

6. PRICE INDICATORS

HOUSING.COM Buy in Nashik | Search: Kamathwade Gaon | Download App | List Property | Saved

Home / Nashik / Kamathwade Gaon / Plot for Sale in Kamathwade Gaon / Residential Plot

Residential Plot | Last updated: Jan 16, 2024

₹88.0 L | EMI starts at 43.09 K

Saotashruni Nagar, Kamathwade Gaon, Nashik

[Contact Seller](#)

No Property images available
[Request Photos](#)

2300 sq.ft Plot Area	3.83 K/sq.ft Avg. Price	20 Year Old Age of property	Immediate Possession status	South-East facing Facing
-------------------------	----------------------------	--------------------------------	--------------------------------	-----------------------------

magicbricks Buy | Rent | Sell | Home Loans

Home > Property in Nashik > Plots for Sale in Nashik > Ashwin Nagar > 280 Sq.yrd

₹1.40 Cr | ₹5556/sqft | [Apply for loan](#) | ONLY ON MAGICBRICKS

Plot For Sale in [View on map](#)

 2 Photos

5 Floors allowed

Plot Area 280 sqyrd -	Any Construction Done No	Status Legal & Infra Status
Boundary Wall Yes	Type Of Ownership Leasehold	Transaction Type Resale

[Contact Owner](#) | [Get Phone No.](#)

Agreement of Assignment

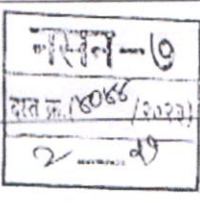
<div style="text-align: center;">  </div> <p>विभाग क्र. १.४८.१ सरकारी मुल्यांकन रु. १३,००,०००/- खरेदी किंमत रु. २१,५०,०००/- मुद्रांक शुल्क रु. १,२९,०००/- नोंदणी फी रु. २१,५००/-</p> <div style="text-align: center; border: 1px solid black; padding: 5px; margin: 10px 0;"> <p>॥श्री॥ करारनामा (अॅग्रीमेंट ऑफ असाईनमेंट)</p> </div> <p>करारनामा (अॅग्रीमेंट ऑफ असाईनमेंट) आज दिनांक ०६ माहे एप्रिल इसवी सन २०२३ रोज ते दिवशी नाशिक मुक्कामी.</p> <div style="display: flex; justify-content: space-between;"> <div style="width: 45%;"> <p>१. श्री. सुरेश जगन्नाथ विसपुते वय: ३९ वर्ष, धंदा: नोकरी, पॅन: ए एच पी वी व्ही ७८३९ जे आधार नं. २०९६ ७७७२ ७२४७</p> <p>२. सौ. शिल्पा सुरेश विसपुते वय: ३४ वर्ष, धंदा: घरकाम, पॅन: ए एल सी पी व्ही ६१८६ एफ आधार नं. ३६५१ ७७४० ७५३२ दोघेही रा. एन-१/इ/३९/०३, विर सावरकर चौक, सिडको, नाशिक-४२२००९.</p> <p style="text-align: center;">यांसी</p> <p>१. श्री. मुकेश उताहार नेरपगार वय: ३९ वर्ष, धंदा: व्यावसाय, पॅन: ए आय आय पी एन ३९३२ सी आधार नं. ५४९६ ३७२८ ५३२०</p> <p>२. सौ. सोनी मुकेश नेरपगार वय: ३२ वर्ष, धंदा: घरकाम, पॅन: सी एल जी पी एन ३६०३ आर आधार नं. २८५८ ९३२३ ७०७० दोघेही रा. एन-१/एफ/०६/०४, राणा प्रताप चौक, सिडको, नाशिक-४२२००९.</p> </div> <div style="width: 5%; text-align: center; font-size: 2em;">}</div> <div style="width: 45%;"> <p style="text-align: center;">लिहून घेणार</p> <p style="text-align: center;">लिहून देणार</p> </div> </div>	<p>कारणे करारनामा (अॅग्रीमेंट ऑफ असाईनमेंट) लिहून देतात तो ऐसा जे की</p> <p>१. मिळकतीचे वर्णन :</p> <p>तुकडी जिल्हा नाशिक पोदतुकडी तालुका नाशिक पैकी नाशिक महानगरपालिका हद्दीतील नाशिक शहरातील व सिटी अॅण्ड इंडस्ट्रीयल डेव्हलपमेंट कॉर्पोरेशन ऑफ महाराष्ट्र लि., (यापुढे सदर संस्थेचा उल्लेख "सिडको" असा साक्षिपत्रेसाठी केलेला आहे) यांच्या अधिपत्याखालील व सिडको यांनी मंजूर केलेल्या तोआऊट प्लॅन प्रमाणे दुसऱ्या (२) योजने मधील नेबरहूड फाल्युन सेक्टर मधील रहिवाशी बांधीव मिळकत यांसी घर / टेनेमेंट क्र. एन-१/एफ/०६/०४ यांसी प्लॉट क्र ३९.६० चौ. मी. व त्यावरील स्किम नुसारचे बांधीव क्षेत्र १८.३० चौ.मी. (प्लॅन नुसार क्षेत्र १८.०६ चौ.मी.) + तळ मजल्या वरील वाढीव बांधीव क्षेत्र १०.०७ चौ.मी. + पहिल्या मजल्या वरील जीन्यासह वाढीव बांधीव क्षेत्र १२.१५६ चौ.मी. असे एकुण बांधीव क्षेत्र ४०.५२६ चौ. मी. यांसी चतुःसिमा खालील प्रमाणे :</p> <p>पुर्वेस : मार्जिनल स्पेस पश्चिमेस : कॉलनी रोड दक्षिणेस : मार्जिनल स्पेस (बोक) उत्तरेस : घर / टेनेमेंट क्र. एन-१/एफ/०६/०३</p> <p>येणेप्रमाणे चतुःसिमेतील घर मिळकत, जल, तर, काष्ट, पापाण, निधी, निक्षेप वगैरे तदंगभूत वस्तुंसह, त्यातील स्वतंत्र विज कनेक्शन, मीटर, फिटिंग, फिक्चर्स, वॉटर कनेक्शन, मीटर, टेरस, जीना इ. वापरणेसह व मला प्राप्त झालेल्या सर्व हक्कांसह तसेच जागे येण्याचे, वागवहिवाटीचे हक्कांसहची व पुर्वापार सर्व हक्कांसहची मिळकत दरोवस्त.</p> <p>यापुढे साक्षिपत्रेसाठी लिहून देणार यांचा उल्लेख "आम्ही" व लिहून घेणार यांचा उल्लेख "तुम्ही" व मिळकतीचा उल्लेख "सदर मिळकत" असा केलेला आहे.</p> <p>२. व्रतन १ मध्ये वर्णन केलेली मिळकत ही लिहून देणार यांचे स्वकष्टार्जित खरेदी मालकीची असून सदरची मिळकत त्यांनी श्री. गोकुळ पांडुरंग बोरसे यांचेकडून डीह ऑफ असाईनमेंट (हरतांतरण दस्त) अन्वये खरेदी घेतलेली आहे. सदरचा दस्त मे. सह दुय्यम निबंधक नाशिक-४ यांचे कार्यालयात अ. नं. ७८३६/२०१८ लगत दि.१२.०९.२०१८ रोजी नोंदवून दिला आहे व तेव्हा पासून सदर मिळकत लिहून देणार यांचे प्रत्यक्ष कब्जे व हिवाटीत आहे.</p>
---	--

Tenement Transfer Order & Possession Receipt



**CITY & INDUSTRIAL DEVELOPMENT CORPORATION
OF MAHARASHTRA LIMITED, NASHIK**

CIN No. U99999MH1970SGC014574 Office of the Administrator,
CIDCO, New Nashik.

NO.CIDCO/ADMN/NSK/8952 Date: 24/09/2018

TENEMENT TRANSFER ORDER

Shri.Gokul Pandurang Borse was Transferred the House No. N9/FE/06/04 in 2nd Housing Scheme at new Nashik under Letter No. Dy.Adm/HS-II/918 Dated 11/05/1982. The Agreement was also executed on 14/01/1996. The cost of the house was fixed at 17,600/- (Rs.Seventy Thousand Six Hundred Only) and accordingly the entire amount has been paid by Shri.Gokul Pandurang Borse. Now after the payment of the cost of the house, Shri.Gokul Pandurang Borse has applied on 31/08/2018 for the transfer of the House Shri.Mukesh Adhar Nernagar & Sau.Soni Mukesh Nernagar and in view of the direction the transfer is permitted on payment of Fixed Transfer charges and the Price paid by allottees. Thus the amount of 9445/- (Rs.Nine Thousand Four Hundred Fourty Five Only) i.e. recovered from Shri.Gokul Pandurang Borse as Transfer Charges of the House No N9/FE/06/04 vide Receipt No. 11550. Dated 14/09/2018.

The Allotment/ Transfer House No. N9/FE/06/04 in 2nd Housing Scheme at New Nashik made of Shri.Gokul Pandurang Borse is cancelled and it is now transferred Shri.Mukesh Adhar Nernagar & Sau.Soni Mukesh Nernagar He shall be liable to pay from Sept. 2018 the Water / Service / Insurance and all other charges as noted in the agreement and breach of condition will be taken serious notice for action in the court of Law.The Agreement should be issued accordingly.



POSSESSION RECEIPT

I, Shri/Smt. G. P. Borse

have this day of 31/08 1982 received possession of the House No. E/6/4 in Sector F at New Nashik.

Before taking over possession, I have verified the fittings, fixtures and amenities in the above house and they are according to the plans and specifications enclosed with the agreement I have inspected the house and satisfied myself. I accept the above said house subject to rectify the complaints which one enclosed herewith I would not claim another house from CIDCO later on.

Date : 31/8/82

Countersigned by the Administrator Date 31/8/82

Possession given on: 31/8/82

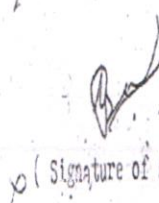
(Signature of Allottee)

Building Plan

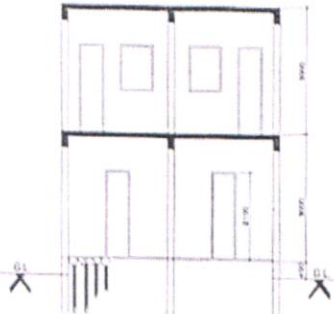

1) PLOT AREA → 39.60 SQ.M.

2) SCHEME BUILTUP → 18.06 SQ.M.

3) FUTURE EXTENTION (ground floor) → 10.07 SQ.M.

4) FIRST FLOOR B/UP → 7.776 SQ.M.

5) STAIRCASE AREA → 4.38 SQ.M.

TOTAL F.F. + STAIRCASE 12.156 SQ.M.

TREAD - 25 CM
RISER - 19 CM.

CIDCO LTD.
PLANNING (NT), NEW AURANGABAD.

**TYPE DESIGN WITH
ADDITIONAL CONST.**

NEW NASHIK.

L.I.G./N-9

HOUSING SCHEME

NO.	LOCATION.
IInd	

SCALE - 1 : 100

DRAWN BY - R.L.NIRHALI

ASST. PLANNER - R.M.MANKAR

ASSO. / SR. PLANNER - R.G.PHADKE

NAME OF TENEMENT HOLDER -
Shri. Gopal Khandanang Borse

TENEMENT NO. - *N-7/E/06/104*

Approved as amended in Red.
 Subject to the Conditions mentioned in
 this office letter No. *16/2022*
 Date: *16/2/2022*



Pranav
 प्रशासक
 लिडको : नाशिक

APPROVING AUTHORITY

OWNER SIGN

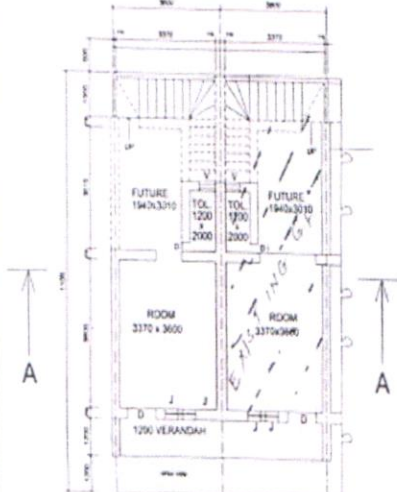

GROUND FLOOR PLAN

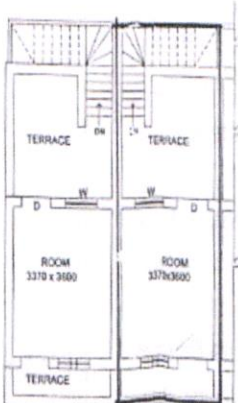

FIRST FLOOR PLAN

NOTE - EXISTING WORKSHOWN IN HATCHING
PROP. WORKSHOWN IN RED COLOUR

As a result of my appraisal and analysis, it is my considered opinion that the **Fair Market Value** for this particular above property in the prevailing condition with aforesaid specification is **₹ 20,23,275.00 (Rupees Twenty Lakh Twenty-Three Thousand Two Hundred Seventy-Five Only)**. The Realizable Value **₹ 19,22,111.00 (Rupees Nineteen Lakh Twenty-Two Thousand One Hundred Eleven Only)** and the Distress value **₹ 16,18,620.00 (Rupees Sixteen Lakh Eighteen Thousand Six Hundred Twenty Only)**.

Place: Nashik

Date: 19.06.2024

For **VASTUKALA CONSULTANTS (I) PVT. LTD.**

**Manoj
Chalikwar**

Digitally signed by Manoj Chalikwar
DN: cn=Manoj Chalikwar, o=Vastukala
Consultants (I) Pvt. Ltd., ou=Mumbai,
email=manoj@vastukala.org, c=IN
Date: 2024.06.19 17:49:20 +05'30'

Director

Auth. Sign.

Manoj B. Chalikwar

Registered Valuer

Chartered Engineer (India)

Reg. No. CAT-I-F-1763

Reg. No. IBBI/RV/07/2018/10366

BOB Empanelment No.: ZO:MZ:ADV:46:941

Manoj B. Chalikwar

The undersigned has inspected the property detailed in the Valuation Report dated _____

on _____. We are satisfied that the fair and reasonable market value of the property is

₹ _____ (Rupees

_____ only).

Date

Signature

(Name & Designation of the Inspecting

Official/s)

Countersigned
(BRANCH MANAGER)

Enclosures	
Declaration-cum-undertaking from the valuer (Annexure- I)	Attached
Model code of conduct for valuer - (Annexure - II)	Attached



Since 1989

Vastukala Consultants (I) Pvt. Ltd.

An ISO 9001 : 2015 Certified Company



(Annexure – I)

7. DECLARATION FROM VALUERS

I, Manoj Chalikwar son of Shri. Baburao Chalikwar declare that:

- a. The information furnished in my valuation report dated 19.06.2024 is true and correct to the best of my knowledge and belief and I have made an impartial and true valuation of the property.
- b. I have no direct or indirect interest in the property valued;
- c. I/ my authorized representative has personally inspected the property on 18.06.2024. The work is not sub - contracted to any other valuer and carried out by myself.
- d. I have not been convicted of any offence and sentenced to a term of imprisonment.
- e. I have not been found guilty of misconduct in my professional capacity.
- f. I have read the Handbook on Policy, Standards and procedure for Real Estate Valuation, 2011 of the IBA and this report is in conformity to the "Standards" enshrined for valuation in the Part - B of the above handbook to the best of my ability.
- g. I have read the International Valuation Standards (IVS) and the report submitted to the Bank for the respective asset class is in conformity to the "Standards" as enshrined for valuation in the IVS in "General Standards" and "Asset Standards" as applicable.
- h. I abide by the Model Code of Conduct for empanelment of valuer in the Bank. (Annexure IV - A signed copy of same to be taken and kept along with this declaration)
- i. I am valuer registered with Insolvency & Bankruptcy Board of India (IBBI).
- j. I am Director of the company, who is competent to sign this valuation report.
- k. Further, I hereby provide the following information.

	Particulars	Valuer comment
1.	Background information of the asset being valued;	The property under consideration is being purchased by Shri.Suresh Jagannath Vispute & Sau.Shilpa Suresh Vispute from Shri.Suresh Adhar Nerpagar & Other 1 as per Agreement of Assignment Dated.06.04.2023
2.	Purpose of valuation and appointing authority	As per the request from Bank of Baroda, Regional Office Branch to assess Fair market value of the property for banking purpose.
3.	Identity of the Valuer and any other experts involved in the valuation;	Manoj B. Chalikwar – Regd. Valuer Sanjay Phadol - Regional Technical Manager Swapnil Wagh - Valuation Engineer Binu Surendran – Technical Manager Chintamani Chaudhari – Technical Officer
4.	Disclosure of Valuer interest or conflict, if any;	We have no interest, either direct or indirect, in the property valued. Further to state that we do not have relation or any connection with property owner / applicant directly or indirectly. Further to state that we are an independent Valuer and in no way related to property owner / applicant
5.	Date of appointment, valuation date and date of report;	Date of Appointment – 18.06.2024 Valuation Date – 19.06.2024 Date of Report – 19.06.2024
6.	Inspections and/or investigations undertaken;	Physical Inspection done on date 18.06.2024
7.	Nature and sources of the information used or relied upon;	<ul style="list-style-type: none"> • Market Survey at the time of site visit • Ready Reckoner rates / Circle rates • Online search for Registered Transactions • Online Price Indicators on real estate portals • Enquiries with Real estate consultants • Existing data of Valuation assignments carried out by us
8.	Procedures adopted in carrying out the valuation and valuation standards followed;	Cost Approach (For building construction) Comparative Sales Method (For Land component)
9.	Restrictions on use of the report, if any;	This valuation is for the use of the party to whom it is addressed and for no other purpose. No responsibility is accepted to any third party who may use or rely on the whole or any part of this valuation. The valuer has no pecuniary interest that would conflict with the proper valuation of the property.
10.	Major factors that were taken into account during the valuation;	Current market conditions, demand and supply position, Residential land size, location, sustained demand for Residential land, all round development of commercial and Residential application in the locality etc.
11.	Major factors that were not taken into account during the valuation;	Nil
12.	Caveats, limitations and disclaimers to the extent they explain or elucidate the limitations faced by valuer, which shall not be for the purpose of limiting his responsibility for the valuation report.	Attached

8. **ASSUMPTIONS, DISCLAIMERS, LIMITATIONS & QUALIFICATIONS**

Value Subject to Change

The subject appraisal exercise is based on prevailing market dynamics as on **19th June 2024** and does not take into account any unforeseeable developments which could impact the same in the future.

Our Investigations

We are not engaged to carry out all possible investigations in relation to the subject property. Where in our report we identify certain limitations to our investigations, this is to enable the reliant party to instruct further investigations where considered appropriate or where we recommend as necessary prior to reliance. Vastukala Consultants India Pvt. Ltd. (VCIPL) is not liable for any loss occasioned by a decision not to conduct further investigations

Assumptions

Assumptions are a necessary part of undertaking valuations. VCIPL adopts assumptions for the purpose of providing valuation advise because some matters are not capable of accurate calculations or fall outside the scope of our expertise, or out instructions. The reliant party accepts that the valuation contains certain specific assumptions and acknowledge and accept the risk of that if any of the assumptions adopted in the valuation are incorrect, then this may have an effect on the valuation.

Information Supplied by Others

The appraisal is based on the information provided by the client. The same has been assumed to be correct and has been used for appraisal exercise. Where it is stated in the report that another party has supplied information to VCIPL, this information is believed to be reliable but VCIPL can accept no responsibility if this should prove not to be so.

Future Matters

To the extent that the valuation includes any statement as to a future matter, that statement is provided as an estimate and/or opinion based on the information known to VCIPL at the date of this document. VCIPL does not warrant that such statements are accurate or correct.

Map and Plans

Any sketch, plan or map in this report is included to assist the reader while visualizing the property and assume no responsibility in connection with such matters.

Site Details

Based on inputs received from Client's representative and site visit conducted, we understand that the subject property is currently a contiguous and non-agricultural land parcel admeasuring **39.60 Sq. M.** and structures thereof. The property is owned by **Shri.Suresh Jagannath Vispute & Sau.Shilpa Suresh Vispute** . Further, VCIPL has assumed that the subject property is free from any encroachment and is available as on the date of the appraisal.

Property Title

Based on our discussion with the Client, we understand that the property is owned **Shri.Suresh Jagannath Vispute & Sau.Shilpa Suresh Vispute**. For the purpose of this appraisal exercise, we have assumed that the subject property has a clear title and is free from any encumbrances, disputes and claims. VCIPL has made no further enquiries with the relevant local authorities in this regard and does not certify the property as having a clear and marketable title. Further, no legal advice regarding the title and ownership of the subject property has been obtained for the purpose of this appraisal exercise. It has been assumed that the title deeds are clear and marketable.



Since 1989

Vastukala Consultants (I) Pvt. Ltd.

An ISO 9001 : 2015 Certified Company



Environmental Conditions

We have assumed that the subject property is not contaminated and is not adversely affected by any existing or proposed environmental law and any processes which are carried out on the property are regulated by environmental legislation and are properly licensed by the appropriate authorities.

Town Planning

The permissible land use, zoning, achievable FSI, area statement adopted for purpose of this valuation is based on the information provided by the Client's representative and the same has been adopted for this valuation purpose. VCIPL has assumed the same to be correct and permissible. VCIPL has not validated the same from any authority.

Area

Based on the documents, we understand that the subject property is contiguous and non-agricultural land parcel admeasuring **39.60 Sq. M.** and structure thereof.

Condition & Repair

In the absence of any information to the contrary, we have assumed that there are no abnormal ground conditions, nor archaeological remains present which might adversely affect the current or future occupation, development or value of the property. The property is free from rat, infestation, structural or latent defect. No currently known deleterious or hazardous materials or suspect techniques will be used in the construction of or subsequent alteration or additions to the property and comments made in the property details do not purport to express an opinion about, or advise upon, the condition of uninspected parts and should not be taken as making an implied representation or statement about such parts

Valuation Methodology

For the purpose of this valuation exercise, the valuation methodology used is Direct Comparison Approach Method and proposed Highest and Best Use model is used for analysing development potential.

The Direct Comparison Approach involves a comparison of the property being valued to similar properties that have actually been sold in arms - length transactions or are offered for sale. This approach demonstrates what buyers have historically been willing to pay (and sellers willing to accept) for similar properties in an open and competitive market and is particularly useful in estimating the value of the land and properties that are typically traded on a unit basis.

In case of inadequate recent transaction activity in the subject micro-market, the appraiser would collate details of older transactions. Subsequently, the appraiser would analyse rental / capital value trends in the subject micro-market in order to calculate the percentage increase / decrease in values since the date of the identified transactions. This percentage would then be adopted to project the current value of the same.

Where reliance has been placed upon external sources of information in applying the valuation methodologies, unless otherwise specifically instructed by Client and/or stated in the valuation, VCIPL has not independently verified that information and VCIPL does not advise nor accept it as reliable. The person or entity to whom the report is addressed acknowledges and accepts the risk that if any of the unverified information in the valuation is incorrect, then this may have an effect on the valuation.

Not a Structural Survey

We state that this is a valuation report and not a structural survey

Other

All measurements, areas and ages quoted in our report are approximate

Legal

We have not made any allowances with respect to any existing or proposed local legislation relating to taxation on realization of the sale value of the subject property. VCIPL is not required to give testimony or to



Since 1989

Vastukala Consultants (I) Pvt. Ltd.

An ISO 9001 : 2015 Certified Company



appear in court by reason of this appraisal report, with reference to the property in question, unless arrangement has been made thereof. Further, no legal advice on any aspects has been obtained for the purpose of this appraisal exercise

Property specific assumptions

Based on inputs received from the client and site visit conducted, we understand that the subject property is currently vacant and Bank Possession, contiguous and non-agricultural land parcel admeasuring **39.60 Sq. M.** and structure thereof.

9. ASSUMPTIONS, CAVEATS, LIMITATION AND DISCLAIMERS

1. We assume no responsibility for matters of legal nature affecting the property appraised or the title thereto, nor do we render our opinion as to the title, which is assumed to be good and marketable.
2. The property is valued as though under responsible ownership.
3. It is assumed that the property is free of liens and encumbrances.
4. It is assumed that there are no hidden or unapparent conditions of the subsoil or structure that would render it more or less valuable. No responsibility is assumed for such conditions or for engineering that might be required to discover such factors.
5. There is no direct/ indirect interest in the property valued.
6. The rates for valuation of the property are in accordance with the Govt. approved rates and prevailing market rates

(Annexure – II)

10. MODEL CODE OF CONDUCT FOR VALUERS

Integrity and Fairness

1. A valuer shall, in the conduct of his/its business, follow high standards of integrity and fairness in all his/its dealings with his/its clients and other valuers.
2. A valuer shall maintain integrity by being honest, straightforward, and forthright in all professional relationships.
3. A valuer shall endeavour to ensure that he/it provides true and adequate information and shall not misrepresent any facts or situations.
4. A valuer shall refrain from being involved in any action that would bring disrepute to the profession.
5. A valuer shall keep public interest foremost while delivering his services.

Professional Competence and Due Care

6. A valuer shall render at all times high standards of service, exercise due diligence, ensure proper care and exercise independent professional judgment.
7. A valuer shall carry out professional services in accordance with the relevant technical and professional standards that may be specified from time to time.
8. A valuer shall continuously maintain professional knowledge and skill to provide competent professional service based on up-to-date developments in practice, prevailing regulations / guidelines and techniques.
9. In the preparation of a valuation report, the valuer shall not disclaim liability for his/its expertise or deny his/its duty of care, except to the extent that the assumptions are based on statements of fact provided by the company or its auditors or consultants or information available in public domain and not generated by the valuer.
10. A valuer shall not carry out any instruction of the client insofar as they are incompatible with the requirements of integrity, objectivity and independence.
11. A valuer shall clearly state to his client the services that he would be competent to provide and the services for which he would be relying on other valuers or professionals or for which the client can have a separate arrangement with other valuers.

Independence and Disclosure of Interest

12. A valuer shall act with objectivity in his/its professional dealings by ensuring that his/its decisions are made without the presence of any bias, conflict of interest, coercion, or undue influence of any party, whether directly connected to the valuation assignment or not.
13. A valuer shall not take up an assignment if he/it or any of his/its relatives or associates is not independent in terms of association to the company.
14. A valuer shall maintain complete independence in his/its professional relationships and shall



Since 1989

Vastukala Consultants (I) Pvt. Ltd.

An ISO 9001 : 2015 Certified Company



conduct the valuation independent of external influences.

15. A valuer shall wherever necessary disclose to the clients, possible sources of conflicts of duties and interests, while providing unbiased services.
16. A valuer shall not deal in securities of any subject company after any time when he/it first becomes aware of the possibility of his / its association with the valuation, and in accordance with the Securities and Exchange Board of India (Prohibition of Insider Trading) Regulations, 2015 or till the time the valuation report becomes public, whichever is earlier.
17. A valuer shall not indulge in "mandate snatching" or offering "convenience valuations" in order to cater to a company or client's needs.
18. As an independent valuer, the valuer shall not charge success fee.
19. In any fairness opinion or independent expert opinion submitted by a valuer, if there has been a prior engagement in an unconnected transaction, the valuer shall declare the association with the company during the last five years.

Confidentiality

20. A valuer shall not use or divulge to other clients or any other party any confidential information about the subject company, which has come to his / its knowledge without proper and specific authority or unless there is a legal or professional right or duty to disclose.

Information Management

21. A valuer shall ensure that he/ it maintains written contemporaneous records for any decision taken, the reasons for taking the decision, and the information and evidence in support of such decision. This shall be maintained so as to sufficiently enable a reasonable person to take a view on the appropriateness of his /its decisions and actions.
22. A valuer shall appear, co-operate and be available for inspections and investigations carried out by the authority, any person authorised by the authority, the registered valuers organisation with which he/it is registered or any other statutory regulatory body.
23. A valuer shall provide all information and records as may be required by the authority, the Tribunal, Appellate Tribunal, the registered valuers organisation with which he/it is registered, or any other statutory regulatory body.
24. A valuer while respecting the confidentiality of information acquired during the course of performing professional services, shall maintain proper working papers for a period of three years or such longer period as required in its contract for a specific valuation, for production before a regulatory authority or for a peer review. In the event of a pending case before the Tribunal or Appellate Tribunal, the record shall be maintained till the disposal of the case.

Gifts and hospitality:

25. A valuer or his / its relative shall not accept gifts or hospitality which undermines or affects his independence as a valuer.

Explanation: For the purposes of this code the term 'relative' shall have the same meaning as defined in clause (77) of Section 2 of the Companies Act, 2013 (18 of 2013).

26. A valuer shall not offer gifts or hospitality or a financial or any other advantage to a public servant or any other person with a view to obtain or retain work for himself / itself, or to obtain or retain an advantage in the conduct of profession for himself / itself.

Remuneration and Costs.

27. A valuer shall provide services for remuneration which is charged in a transparent manner, is a reasonable reflection of the work necessarily and properly undertaken, and is not inconsistent with the applicable rules.
28. A valuer shall not accept any fees or charges other than those which are disclosed in a written contract with the person to whom he would be rendering service.

Occupation, employability and restrictions.

29. A valuer shall refrain from accepting too many assignments, if he/it is unlikely to be able to devote adequate time to each of his/ its assignments.
30. A valuer shall not conduct business which in the opinion of the authority or the registered valuer organisation discredits the profession.

Place: Nashik

Date: 19.06.2024

For VASTUKALA CONSULTANTS (I) PVT. LTD.

Manoj
Chalikwar

Digitally signed by Manoj Chalikwar
DN: cn=Manoj Chalikwar, o=Vastukala
Consultants (I) Pvt. Ltd., ou=Mumbai,
email=manoj@vastukala.org, c=IN
Date: 2024.06.19 17:49:30 +05'30'

Director

Auth. Sign.

Manoj B. Chalikwar
Registered Valuer
Chartered Engineer (India)
Reg. No. CAT-I-F-1763
Reg. No. IBBI/RV/07/2018/10366
BOB Empanelment No.: ZO:MZ:ADV:46:941



Since 1989

Vastukala Consultants (I) Pvt. Ltd.

An ISO 9001 : 2015 Certified Company

